

INSTALLATION AND SERVICE MANUAL

INDOOR MAKE-UP AIR UNIT ARRANGEMENTS FOR HEATING, COOLING AND VENTILATING SYSTEMS

ATTENTION: READ THIS MANUAL, INDOOR DUCT FURNACE DISM MANUAL (EVAPORATIVE OR COOLING COIL MANUALS IF APPLICABLE), UNIT SUBMITTAL DATA SHEETS AND ALL LABELS ATTACHED TO THE UNIT CAREFULLY BEFORE ATTEMPTING TO INSTALL, OPERATE OR SERVICE THESE UNITS! CHECK UNIT DATA PLATES FOR TYPE OF GAS AND ELECTRICAL SPECIFICATIONS AND MAKE CERTAIN THAT THESE AGREE WITH THOSE AT THE POINT OF INSTALLATION. RECORD THE UNIT MODEL NUMBER AND SERIAL NO.(S) IN THE SPACE PROVIDED. RETAIN THIS DOCUMENT FOR FUTURE REFERENCE.

Model No. _____

Serial No. _____

FOR YOUR SAFETY

The use or storage of gasoline or other flammable vapors or liquids in open containers in the vicinity of this appliance is hazardous.

FOR YOUR SAFETY

- If you smell gas:
1. Open windows.
 2. Don't touch electrical switches.
 3. Extinguish any open flames.
 4. Immediately call your gas supplier.

▲ WARNING Improper installation, adjustment, alteration, service or maintenance can cause property damage, injury or death. This appliance must be installed by a licensed contractor or qualified service personnel. Read these installation, operating and maintenance instructions thoroughly before installing or servicing this equipment.

**APPROVED FOR USE IN CALIFORNIA
WHEN UNITS ARE EQUIPPED WITH INTERMITTENT (SPARK) IGNITION.**

▲ WARNING Install, operate and maintain unit in accordance with manufacturer's instructions to avoid exposure to fuel substances or substances from incomplete combustion which can cause death or serious illness. The state of California has determined that these substances may cause cancer, birth defects, or other reproductive harm. Install and Service this product to avoid exposure to airborne particles of glasswool fibers and/or ceramic fibers known to the State of California to cause cancer through inhalation.

INSTALLER'S RESPONSIBILITY

Installer Please Note: This equipment has been test fired and inspected. It has been shipped free from defects from our factory. However, during shipment and installation, problems such as loose wires, leaks or loose fasteners may occur. **It is the installer's responsibility to inspect and correct any problems that may be found.**

RECEIVING INSTRUCTIONS

Inspect shipment immediately when received to determine if any damage has occurred to the unit during shipment. After the unit has been uncrated, check for any visible damage to the unit. If any damage is found, the consignee should sign the bill of lading indicating such damage and immediately file claim for damage with the transportation company.

IMPORTANT: Look in direction of unit air flow to determine whether unit is right hand or left hand accessible.



MESTEK, INC.

260 NORTH ELM ST., WESTFIELD, MA 01085

TEL: (413) 564-5540

www.mestek.com

TABLE OF CONTENTS

I. RECEIVING & PRE-INSTALLATION INSTRUCTIONS	2
II. GENERAL INSTALLATION SAFETY REQUIREMENTS (throughout IOM)	3, 4
Rigging	4
III. INSTALLATION	
Location	5
Combustion Air Considerations	5
Mounting / Locations	5
Suspension	5
Mounting on Field Furnished Supports	6
Installation Clearances	6, 7
Access Panel Removal	7
Venting	7
Air for Combustion	7
Duct Connections	7, 8
Gas Piping	8
Modulating Gas Control	8, 9
Electrical Connections	9, 10
DX Coil Equipped Units	10
Chilled Water Coil Equipped Units	10
Evaporative Cooling Equipped Units	10
IV. OPERATION	
General Information	11
Gas Control System	11
Optional Gas Controls	11, 12
Air Handling Requirements and Adjustments	12, 13
Lighting	13
Gas Input Adjustment	13, 14
Pilot Adjustment	14
Primary Air Shutter Adjustment	14
Controls	14
V. START UP	14, 15
VI. MAINTENANCE	15 thru 18
VII. TROUBLESHOOTING	19 thru 24
VIII. REPLACEMENT PARTS	24
IX. SERVICE NOTE	24
X. WARRANTY	24
Canadian Installations	25
XI. DIMENSIONAL DATA	26 thru 29
XII. MOTOR ELECTRICAL DATA	30
XIII. UNIT/SHIP WEIGHTS	31
XIV. COOLING COIL DIMENSIONAL DATA	32
XV. CENTER OF GRAVITY	32, 33
XVI. UNIT NUMBER DESCRIPTION	34, 35
XVII. START UP SHEET	36

Unless otherwise specified, the following conversions may be used for calculating SI unit measurements:

1 foot = 0.305 m	1 inch water column = 0.249 kPa
1 inch = 25.4 mm	1000 Btu per hour = 0.293 kW
1 psig = 6.894 kPa	1000 Btu/Cu. Ft. = 37.5 MJ/m ³
1 pound = 0.435 kg	liter/second = CFM x 0.472
1 gallon = 3.785 L	meter/second = FPM ÷ 196.8
1 cubic foot = 0.028 m ³	

The following terms are used throughout this manual to bring attention to the presence of potential hazards or to important information concerning the product:

▲ DANGER Indicates an imminently hazardous situation which, if not avoided, will result in death, serious injury or substantial property damage.

▲ WARNING Indicates an imminently hazardous situation which, if not avoided, could result in death, serious injury or substantial property damage.

▲ CAUTION Indicates an imminently hazardous situation which, if not avoided, may result in minor injury or property damage.

NOTICE: Used to notify of special instructions on installation, operation or maintenance which are important to equipment but not related to personal injury hazards.

I. RECEIVING INSTRUCTIONS

Inspect shipment immediately when received to determine if any damage has occurred to the crate during shipment.

After the unit has been uncrated, check for any visible damage to the unit. Check motor position and turn blower wheel to determine if damage has occurred to these critical parts.

If any damage is found, the consignee should sign the bill of lading indicating such damage and immediately file claim for damage with transportation company.

PRE-INSTALLATION INSTRUCTIONS

When the unit is received and uncrated, check the external data plate and all labels on the unit for type of gas, electrical, and operational specifications to confirm that these agree with those at point of installation. The unit is equipped with an Indoor Duct Furnace; also check the data plate and all labels located on each furnace.

Every Make-Up Air Unit will include an informational packet which will include the following: This make-up air manual, duct furnace, evaporative cooler/cooling coil manuals (if applicable to the unit order), wiring diagram(s), and special controls/data sheets.

▲ WARNING Failure to comply with the general requirements may result in extensive property damage, severe personal injury or death.

NOTICE: It is the equipment owner's responsibility to provide any scaffolding or other apparatus required to perform emergency service or annual/periodic maintenance to this equipment.

II. GENERAL SAFETY REQUIREMENTS

▲ WARNING Open all disconnect switches before installing the unit. If the power disconnect is out of sight, lock it in the open position and tag it to prevent unexpected application of power. Failure to do so may result in personal injury or death from electrical shock.

▲ WARNING Failure to comply with the general requirements may result in extensive property damage, severe personal injury or death.

▲ WARNING Never service any component without first disconnecting all electrical and gas supplies to the unit or severe personal injury or death may occur.

1. Installation must be made in accordance with local codes, or in absence of local codes, with ANSI Standard Z223.1-1996 (N.F.P.A. No 54) "National Fuel Gas Code", or the latest edition of. All ANSI and NFPA Standards referred to in these installation instructions are the ones that were applicable at the time the design of this appliance was certified. The ANSI Standards are available from the American Gas Association, 1515 Wilson Boulevard, Arlington, Virginia 22209. The NFPA Standards are available from the National Fire Protection Association, Batterymarch Park, Quincy, Massachusetts 02269. The heaters are designed for use in airplane hangers when installed in accordance with ANSI/NFPA No. 409 and in public garages when installed in accordance with the NFPA No. 88A and NFPA No. 88B.
2. If installed in Canada, the installation must conform with local building codes, or in the absence of local building codes, with the current CGA-B149.1 or B149.2 "Installation Codes for Gas Burning Appliances and Equipment". These indoor duct furnaces have been designed for and certified to comply with CGA 2.6.
3. No alterations are to be made on this equipment.

The duct furnace section of these make-up air units are certified by the American Gas Association for use with natural and LP (propane) gases!

▲ WARNING Do not alter the duct furnace in any way or damage to the unit, severe personal injury or death will occur.

4. Make certain that the power sources conform to the requirements of the heater.

5. Follow installation instructions CAREFULLY to avoid creating unsafe conditions. All wiring should be done and checked by a qualified electrician, using copper wire only. All gas connections should be made and leak-tested by a suitably qualified individual, per instructions in this manual.

6. Use only the fuel for which the heater is designed (see nameplate). Using LP gas in a heater that requires natural gas, or vice versa, will create the risk of gas leaks, carbon monoxide poisoning and explosion.

▲ WARNING Do not attempt to convert the heater for use with a fuel other than the one intended. Such conversion is dangerous, as it could create unsafe conditions that result in death, serious injury or substantial property damage.

7. Make certain that power source conforms to electrical requirements of heater. Disconnect power before installing or servicing heater. If power disconnect is out of sight, lock it in open position and tag it to prevent unexpected application of power. Failure to do so could result in fatal electric shock.

▲ WARNING Do not depend upon a thermostat or other switch as the sole means of disconnecting power when installing or servicing heater. Always disconnect power at main circuit breaker as described above. Failure to do so could result in fatal electric shock.

8. Special attention must be given to any grounding information pertaining to this heater. To prevent the risk of electrocution, the heater must be securely and adequately grounded. This should be accomplished by connecting a grounded conductor from the service panel to the conduit box of the heater. To ensure proper ground, the grounding means must be tested by qualified field electrician.

9. Do not insert fingers or foreign objects into the heater or its air moving device. Do not block or tamper with the heater in any manner while in operation or just after it has been turned off, as some parts may be hot enough to cause injury.

10. This heater is intended for general heating applications ONLY. It must NOT be used in potentially dangerous locations such as flammable explosive, chemical-laden or wet atmospheres.

In cases in which property damage may result from malfunction of the heater, a backup system or a temperature sensitive alarm should be used.

▲ CAUTION The open end of gas piping systems being purged shall not discharge into areas where there are sources of ignition or into confined spaces **UNLESS** precautions are taken as follows: (1) By ventilation of the space, (2) control of purging rate, (3) elimination of all hazardous conditions. All precautions must be taken to perform this operation in a safe manner!

LOCATIONS TO AVOID

Unit heaters should not be installed within corrosive or flammable atmospheres. Do not locate any gas fired heater where air for combustion contains chlorinated vapors or acid fumes. Avoid locations where extreme drafts can affect burner operation.

▲ CAUTION Presence of these air impurities can cause premature failure of the heat exchanger and void the warranty (See limited warranty on page 24).

The venting system must be installed in accordance with heater manufacturer's instructions. The venting system is an integral part of the unit and **must not be altered in the field!**

RIGGING

Rig unit using either belt or cable slings. Use spreader bars to protect the top of the unit when it is lifted. See Figures 1 and 2. Make sure all hardware used in the lifting/mounting process is tightened and secured.

On units with a total length of less than 104" (2642mm), excluding evaporative cooler, two holes are provided in the base rail on each side of the unit. Slide pipes beneath the unit through these holes and attach rigging to pipes for lifting the unit.

On units with a total length of a 104" (2642mm) or greater, excluding evaporative cooler, lifting lugs/brackets attached to the base rail are provided. Once the unit is set in place these lifting brackets may be removed if required.

Attach rigging to lugs/brackets for lifting the unit. For distance between lifting lugs/brackets and total unit lengths, refer to the Dimensional Data section of this manual. Also see Center of Gravity and Weights sections in this manual prior to lifting and apply accordingly to the lifting process.

Figure 1 - Hoisting of Make-Up Air Unit Without Lifting Brackets

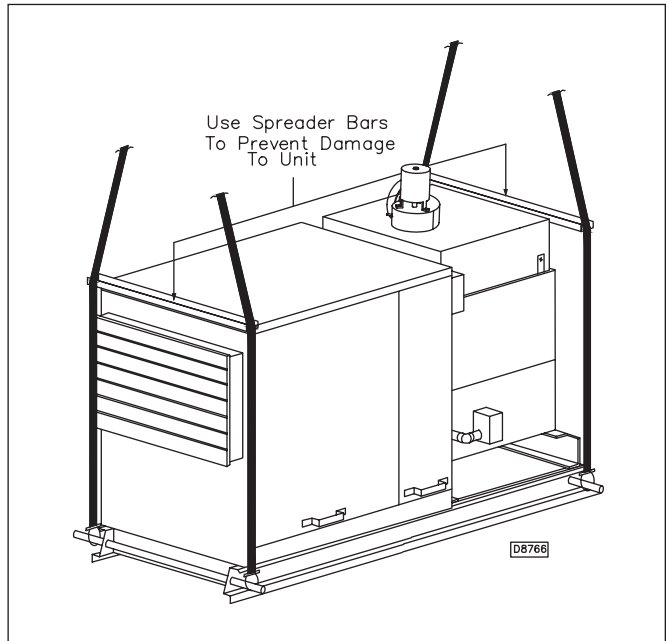
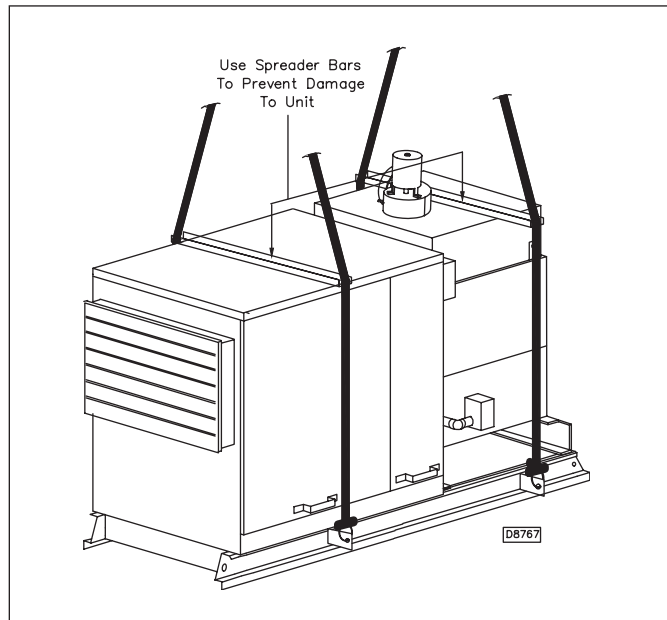

Figure 2 - Hoisting of Make-Up Air Unit With Lifting Brackets



III. INSTALLATION

LOCATION

Before placing the Make-Up Air unit in its permanent location, make certain that the structure is capable of carrying the additional load of this equipment. Check the unit weight given at the end of this manual.

Refer to Installation Clearances section for required clearances to combustible material, and Figure 5 for manufacturer's recommendations.

▲ WARNING Do not place unit in a location where service personnel can not safely service this equipment or personal injury could result.

NOTICE: When selecting a location for these Make-Up Air Units, both the size of the unit and the heating requirements of the building must be considered.

COMBUSTION AIR CONSIDERATIONS

The presence of chlorine vapors or other corrosive vapors in the combustion air supply for gas-fired heating equipment presents a potential corrosive hazard. Chlorine will, when exposed to flame, precipitate from the compound (usually freon or degreaser vapors) and go into solution with any condensation that is present in the heat exchanger or associated parts. The result is hydrochloric acid which will readily attack all metals, including 300 grade stainless steel. Care should be taken to separate these vapors from the combustion process.

MOUNTING HEIGHT

1. When a Gas Fired Make-Up Air Handler is discharging directly into the heated space, a mounting height of eight feet (2.4m) above the floor is recommended. Less efficient air distribution results at higher levels.
2. When Gas Fired Indoor Make-Up Air Handlers are installed in airplane hangars, NFPA specifies that the units must be at least ten feet (3.0m) above the upper surface of wings or engine enclosures of the highest aircraft to be stored in the hangar. This measurement should be made from the wing or engine enclosure (whichever is higher from the floor) to the bottom of the heater. Heaters must be installed at least eight feet (2.4m) above the floor in shops, offices, and other sections of the hangar where aircraft are not stored or housed. Refer to NFPA 409 Aircraft Hangars.

3. In parking structures, Gas Fired Indoor Make-Up Air Handlers must be installed so that the burner flames are located 18 in. (45mm) above the floor or protected by a partition not less than 18 in. (457mm) high as specified in NFPA 88A Parking Structures.
4. In public repair garages, Gas Fired Make-Up Air Handlers must be installed in a detached building or room separated from repair areas as specified in NFPA 88B Repair Garages.

SUSPENSION

▲ WARNING The unit should never be lifted by the fan housing, motor mounting, grille or flue connection. These are not designed to support the total weight and may break, causing personal injury or unit damage.

Units can be set on supports or suspended by rod hangers from the sub-frame (and lifting brackets).

▲ CAUTION Any unit that has a side base rail longer than 104" (2.6m) requires additional field furnished supports by a qualified installer. Refer to all dimensional data and center of gravity information in this manual. If further information is required, contact the manufacturer's technical service department.

The unit must be hung level from side to side and front to back, using the four ($9/16$ " diameter) hanging holes (see Figure 3) in the skid rail, and $3/8$ " or $1/2$ " threaded rod or pipe.

▲ WARNING Make certain that the structure to which the heater is to be mounted is capable of supporting its weight. Under no circumstances must the gas lines, the venting system or the electrical conduit be used to support the heater; or should any other objects (i.e. ladder, person) lean against the heater, gas lines, venting system or the electrical conduit for support.

Figure 3

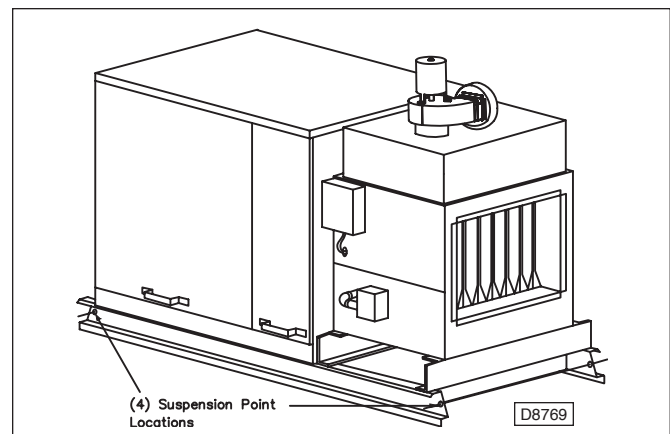

MOUNTING ON FIELD FURNISHED SUPPORTS

Single, double, triple duct furnace models have base rails which are suitable for mounting either directly on solid planking or steel channels. (Refer to Figure 4).

Figure 4

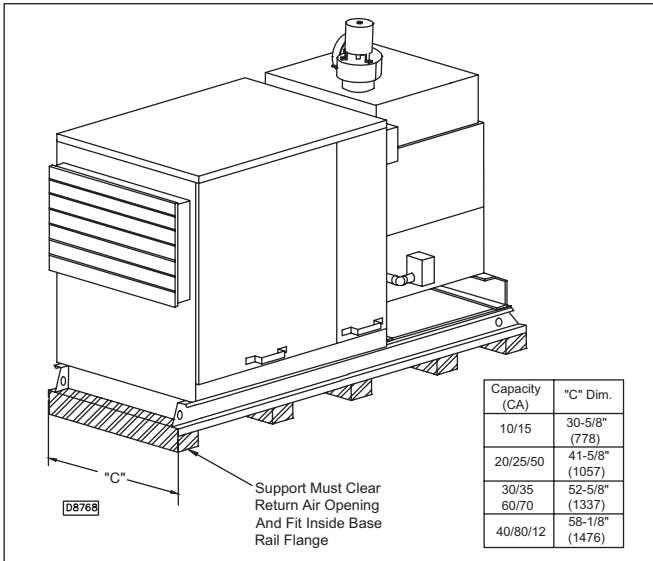

Every gas appliance should be located with respect to building construction and other equipment so as to permit access to the unit. Clearances between vertical walls and the vertical sides of the heater should be no less than 6 inches (152mm). Minimum clearance between the top of the heater and the ceiling is 6 inches (152mm). The minimum clearance from combustibles to the bottom of the furnace is 6 inches (the distance between the unit skid rail bottom and the furnace bottom is approximately 7 inches (178mm) which meets this 6 inch clearance requirement to combustible materials). The minimum clearance from combustibles to the flue collector is 6 inches (152mm). Adequate clearance must be maintained around all openings into the combustion chamber. Adequate clearance should be planned for the width of the unit to pull out the burner drawer. See Figure 5 and Table #T4088-B, D.

A pilot burner plate is provided in the Duct Furnace for easy access to the pilot burner and ignition system without opening burner drawer compartment. Accessibility is also provided for the safety switches included with your unit without removal of jacketry. Refer to the maintenance section and the Indoor Duct Furnace manual for more information.

INSTALLATION CLEARANCES

Minimum clearances to combustible material are shown on the unit data plate. It is important that clearances be maintained for servicing the unit, and that minimum clearances are provided from the unit to combustible material. Clearances around the field installed optional outside air hood (if unit is to be connected to one) must be unobstructed. See Figure 5.

▲ WARNING The unit should never be lifted by furnace sections, blower housing/filter/sections, motor mounts or flue connections. These are not designed to support total weight of the unit, and may break, causing personal injury or property damage!

Figure 5 - Manufacturer's Recommended Service Clearances

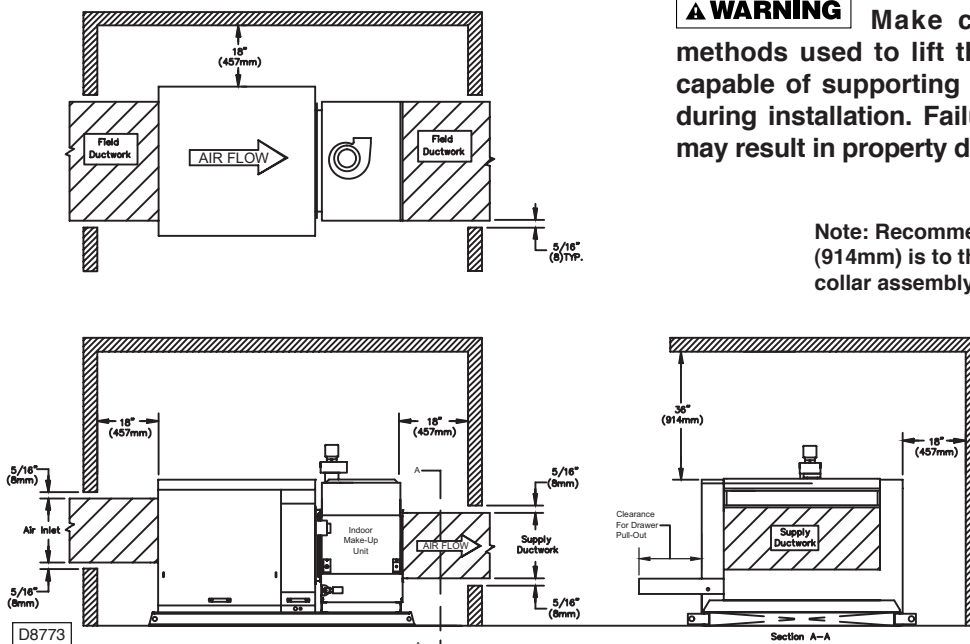

▲ WARNING Make certain that the lifting methods used to lift the Make-Up Air Unit are capable of supporting the weight of the heater during installation. Failure to heed this warning may result in property damage or personal injury.

▲ WARNING Make certain that the structure to which heater is to be mounted is capable of safely supporting its weight. Under no circumstances must the gas lines or the electrical conduit be used to support the heater. Failure to heed these warnings may result in property damage, personal injury or death.

▲ WARNING Open all disconnect switches before installing the unit. Failure to do so may result in personal injury or death from electrical shock.

ACCESS PANEL REMOVAL

The air handler section(s) of this unit are equipped with hinged access doors. The hinged doors include dual, quick opening tool-less latches and full perimeter gasketing to ensure a water resistant seal. Door stops are included to guard against closure while open.

The furnace section service panel is easily accessible - simply remove the mounting screws on the lower jacket panel to disengage and remove the panel; repeat procedure for installing back in place. **See the maintenance section and the duct furnace manual for more information regarding burner drawer removal/accessibility.**

VENTING†

All venting installations shall be in accordance with the latest edition of Part 7, "Venting of Equipment", of the National Fuel Gas Code, ANSI Z223.1-1996 (or the latest edition), or applicable provisions of local building codes.

▲ WARNING **CARBON MONOXIDE!** Your venting system must not be blocked by any snow, snow drifts or any foreign matter. Inspect your venting system to ensure adequate ventilation exists at all times! Failure to heed these warnings could result in Carbon Monoxide Poisoning (symptoms include grogginess, lethargy, inappropriate tiredness, or flu-like symptoms).

▲ WARNING The venting is an integral part of the unit and must not be altered in the field.

Power Vented units feature a factory installed power venter and sealed flue collector that controls combustion and excess air during the on-cycle.

VENT SYSTEMS - TERMINATION CLEARANCE REQUIREMENTS

Structure/Object	Minimum Clearances for Termination Locations	
	USA	CANADA
Door, window, or gravity vent inlet; combustion air inlet for other appliances	9 inches for 10,000 to 50,000 BTU/Hr input; 12 inches for input exceeding 50,000 BTU/Hr.	9 inches (230mm) for 10,000 to 50,000 BTU/Hr input; 12 inches (305mm) for input exceeding 50,000 BTU/Hr.
Forced air inlet within 10 feet	3 feet above	6 feet (1.8m)
Adjoining building or parapet	10 feet	10 feet (3.04m)
Adjacent public walkways	7 feet above grade	7 feet (2.1m) above grade
Electric, gas meters & regulators	4 feet horizontal	3 feet (0.9m) horizontally from meter/regulator assembly. 6 feet (1.8m), any direction, from a gas service regulator vent outlet
Above grade level *	1 foot	1 foot (0.3m)

* Minimum above maximum snow depth, or per local code, whichever is greater.

†Refer to the Indoor Duct Furnace Manual for more venting requirements.

AIR FOR COMBUSTION

Appliances shall be installed in a location in which the facilities for ventilation permit satisfactory combustion of gas, proper venting, and the maintenance of ambient temperature at safe limits under normal conditions for use.

Appliances shall be located in such a manner as not to interfere with proper circulation of air within the confined space. When buildings are so tight that normal infiltration does not meet air requirements, outside air shall be introduced per Sections 1.3.4.2 and 1.3.4.3 of ANSI Z223.1 for combustion air requirements. A permanent opening or openings having a total free area of not less than one square inch per 5,000 Btu/Hr of total input rating of all appliance within the space shall be provided. Refer to the Indoor Duct Furnace Manual supplied with your unit for more requirements.

DUCT CONNECTIONS

All ductwork must be properly supported so that no strain is put on the unit. Do not alter or bend the discharge duct flanges supplied on your make-up air unit.

Duct connections must have a removable access panel in the duct which is connected to a duct furnace. The duct openings shall be accessible when the unit is installed in service, and shall be of such size that smoke or reflected light may be observed inside the casing to indicate the presence of leaks in the heating element. The covers for the panels shall be attached in such a manner as to prevent leaks. Ducts (or optional outside air hoods) exposed to the outdoors must be insulated and sealed to prevent water from entering either the unit or building through the duct.

If a single, double or triple duct furnace only unit is connected to a return air duct, or any other inlet air restriction, the appliance shall be installed on the positive pressure side of the air circulating blower.

When connecting return air duct to Standard or High CFM cabinets, attach duct to return air opening flange when no dampers are used. Otherwise, if dampers are used, attach return air duct around collar at bottom of damper assembly. Also refer to the Dimensional Data section of this manual, Submittal Data Sheets and Indoor Duct Furnace Manual specified for your unit.

GAS PIPING††

All gas piping must be installed in accordance with local codes. It is required that a ground union be installed adjacent to the gas valve of each duct furnace, and a ground union be installed just external of each duct furnace for unit servicing. On vertical runs, a drip leg should be provided upstream of any control manifold. A gas shutoff valve should be, or may be required by local codes, installed upstream of the external ground union for each duct furnace. A 1/8 inch N.P.T. plugged tapping, accessible for test gauge connection, must be installed immediately upstream of the unit gas supply connection.

†† For complete Gas Piping installation, see the Indoor Gas-Fired Duct Furnace Installation and Service Manual.

Gas piping must be installed to allow for removal of burner drawer for unit maintenance. Refer to Figure 5, and the maintenance section.

▲ WARNING To avoid equipment damage or possible personal injury, do not connect gas piping to this unit until a supply line pressure/leak test has been completed. Connecting the unit before completing the pressure/leak test may damage the unit gas valve and result in a fire hazard.

▲ CAUTION Do not rely on a gas shutoff valve to isolate the unit while conducting gas pressure/leak tests. These valves may not be completely shutoff, exposing the unit gas valve to excessive pressure, resulting in damage.

▲ CAUTION Do not over-tighten the inlet gas piping at unit gas valve or stresses that could crack the valve may result.

▲ WARNING Never use an open flame to detect gas leaks. Explosive conditions may exist which would result in personal injury or death.

The gas line should be supported so that no strain is placed on the unit. Pipe compounds which are not soluble to liquid petroleum gases must be used on threaded joints.

The appliance and its individual shutoff valve must be disconnected from the gas supply piping system during any pressure testing of that system at test pressures in excess of 1/2 psig (3.5 kPa).

The appliance must be isolated from the gas supply piping system by closing the individual manual shutoff valve during any pressure testing of the gas supply piping system at test pressures equal to or less than 1/2 psig (3.5 kPa).

For additional gas piping information, including pipe sizing and drip leg installation, refer to Indoor Gas-Fired Duct Furnace Installation and Service Manual.

For additional piping information, refer to the National Fuel Gas Code Z233.1 (latest edition).

NOTICE: If the gas duct furnace is to be fired with LP gas, consult local LP gas dealer for piping size information.

NOTICE: Unit installation for use with propane (bottled) gas must be made by a qualified LP gas dealer or installer. He will insure proper joint compounds are used for making pipe connections; that air is purged from lines; that a thorough test is made for leaks before operating the unit; and that it is properly connected to propane gas supply system.

Before any connection is made to an existing line supplying other gas appliances, contact the local gas company to make certain that the existing line is of adequate size to handle the combined load.

Check all connections for leaks with soap solution.

MODULATING GAS CONTROL (OPTIONAL)*

Electronic: On units equipped with electronic modulating control, follow control manufacturer's installation instructions for sensing of outlet air temperature.

***Also refer to the Indoor Duct Furnace Installation Manual supplied with your unit.**

ELECTRICAL CONNECTIONS



▲ WARNING

HAZARDOUS VOLTAGE!
DISCONNECT ALL ELECTRIC POWER INCLUDING REMOTE DISCONNECTS BEFORE SERVICING. Failure to disconnect power before servicing can cause severe personal injury or death.

All electrical connections must conform to: ANSI/NFPA No. 70-1996 (or latest edition) National Electrical Code and applicable local codes. In Canada, to the Canadian Electrical Code, Part I CSA Standard C22.1.

The Make-Up Air packaged unit is wired at the factory and ready to be connected. Actual unit wiring will differ according to the options chosen. Each unit is shipped with its own wiring diagram; refer to this wiring diagram for all electrical connections to the unit.

All electrical connections, line voltage and thermostat, are made in the Electrical Cabinet (See Figure 7). Line voltage connections are made at the High Voltage Terminal Block. Thermostat connections are made at the Main Connection Board (See Figure 8).

▲ CAUTION Do not use any tools (i.e. screwdriver, pliers, etc.) across terminals to check for power. Use of a voltmeter is recommended.

Locate the thermostat in accordance with the instructions supplied with the thermostat. All field wiring must have a minimum temperature rating of 85°C (185°F). Control wiring shall be a minimum of 18 gauge wire size. Control wiring must be sized for length of run.

Locate line voltage disconnect box per local codes. If mounting the disconnect box to the unit, never mount it to a unit access panel. Possible locations include the front of the blower or filter section (See Figure 9). Electrical conduit must be routed so as not to interfere with removal of any access panel.

NOTICE: Should any original wire supplied with the unit have to be replaced, it must be replaced with wiring having a temperature rating of at least 105°C (221°F).

Figure 7 - Make-Up Air Unit-Standard Blower Cabinet, Single Duct Furnace with Various Options Shown

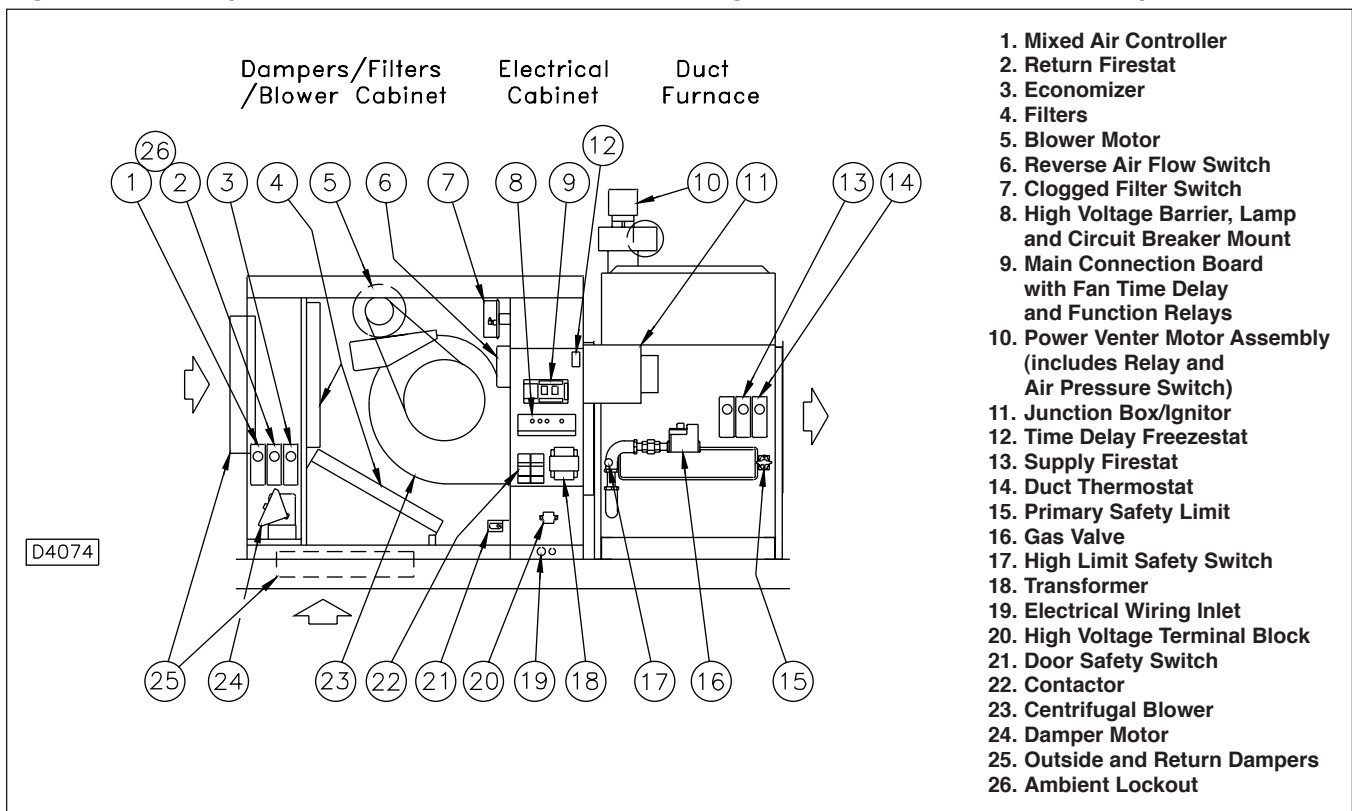

Figure 8 - Electrical Cabinet

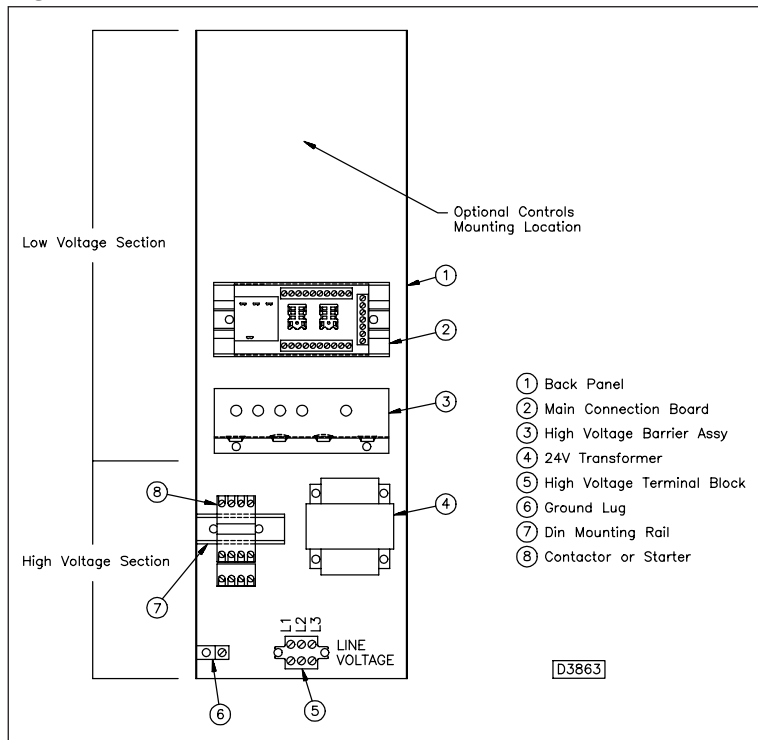
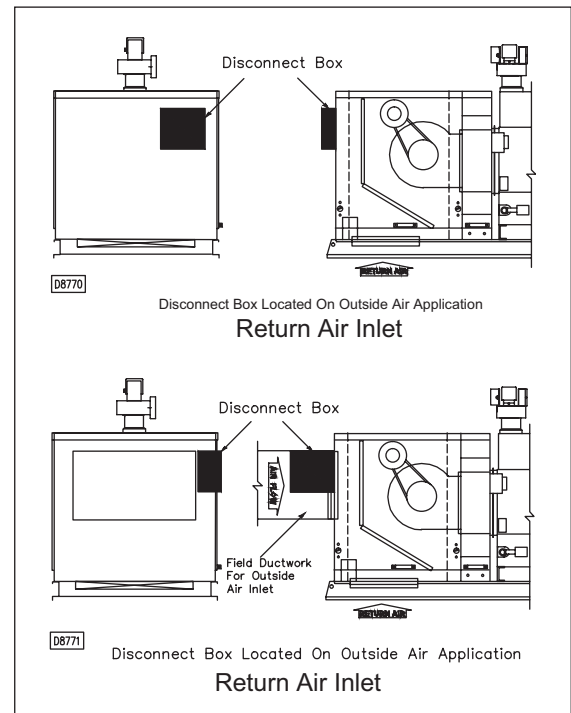

Figure 9 - Disconnect Box Locations



DX COIL EQUIPPED UNITS (OPTIONAL)

See Coil Installation/Maintenance Manual for Refrigerant Piping, Liquid and Suction Line Components, Refrigerant Charging and Thermal Expansion Valve Adjustment. Remove coil cabinet access door located next to blower section. Cut holes in fixed door to allow suction and liquid line passage. Provide weatherproof seal around suction and liquid lines at piping plate when installed.

The DX Coil has a 300 ft/min. (1.524 m/s) minimum and a 600 ft/min. (3.048 m/s) maximum velocity through the coil requirement. This is due to prevention of coil icing or condensate blow-off. To calculate the velocity through the coil, apply the following formula:

$$\text{Velocity through the coil} = \frac{\text{Cooling Air Flow in CFM (m}^3\text{/s)}}{\text{Coil Surface Area in ft}^2 \text{ (m}^2\text{)}}$$

Condensate Drain piping must have a P-trap in line immediately downstream of drain pan connection, external to the unit, to prevent possible outside air leakage into unit. The P-trap shall be of sufficient differential to overcome negative pressure of the indoor air blower. A minimum height difference of 2" (51mm) is required (See Figure 10). Before unit operation begins, the P-trap must be primed with either water (summer) or glycol (winter).

CHILLED WATER COIL EQUIPPED UNITS (OPTIONAL)

See Coil Installation/Maintenance Manual for General Coil Piping Recommendations. Remove coil cabinet access door, cut holes in door to allow chilled water piping passage. Provide weatherproof seal around chilled water pipes at piping plate when installed.

The Chilled Water Coil has a 600 ft/min (3.048 m/s) maximum velocity through the coil requirement. This is due to prevention of condensate blow-off. To calculate the velocity through the coil apply the following formula:

$$\text{Velocity through the coil} = \frac{\text{Cooling Air Flow in CFM (m}^3\text{/s)}}{\text{Coil Surface Area in ft}^2 \text{ (m}^2\text{)}}$$

Condensate Drain piping must have a P-trap in line immediately downstream of drain pan connection, external to the unit, to prevent possible outside air leakage into unit. The P-trap shall be of sufficient differential to overcome negative pressure of the indoor air blower. A minimum height difference of 2" is required (See Figure 10). Before unit operation begins, prime P-trap with either water (summer) or glycol (winter).

EVAPORATIVE COOLER EQUIPPED UNITS (OPTIONAL)

Refer to Evaporative Cooler Installation and Service Manual for water and electrical connections.

IV. OPERATION

GENERAL INFORMATION

Refer to Indoor Gas-Fired Duct Furnace Installation and Service Manual for specific information regarding the heating operation of this unit.

All units are equipped with an intermittent ignition pilot system. The pilot is lit and extinguished each cycle of unit heating operation.

On natural gas units, the ignitor will continue to spark and pilot gas will continue to flow until the pilot flame is proven.

LP (propane) units are equipped with 100% lockout. The lockout function shuts off the main and pilot gas valves if the pilot gas fails to ignite within 90 seconds of the onset of trial for ignition.

The gas control system operates at 24 VAC and is supplied by a stepdown transformer found in the electrical cabinet that will match the unit line voltage specified. See Figure 7 for unit controls location.

Figure 10 - Drain Pan Connection

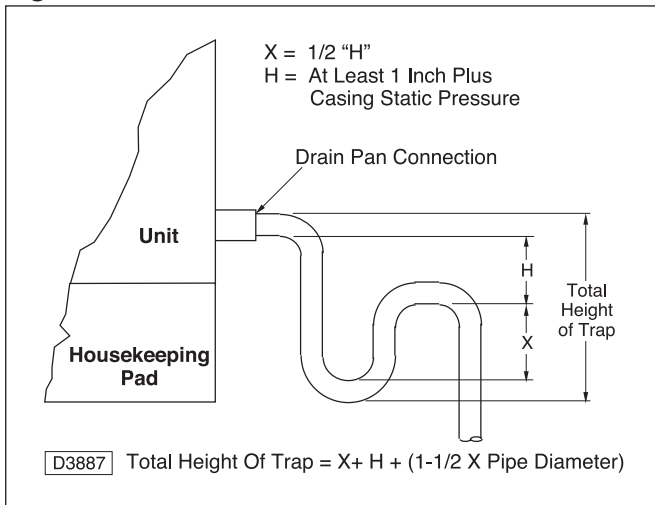

Do not use a thermostatic fan control switch when either two-stage firing or modulated gas controls are used.

GAS CONTROL SYSTEM

The standard unit comes equipped for single stage operation. Unit heating operation is accomplished at full input.

Each duct furnace is equipped with an individual ignition control system which consists of the following components: ignition control module, gas valve and pilot burner.

The **ignition control module** is the heart of the ignition control system. This control initiates all gas flow, provides means to light the pilot burner, proves and monitors the pilot burner operation.

The **gas valve** consists of two operators which provide gas to the pilot and main burners. Both operators are energized and de-energized by the ignition control module each heating cycle.

The **pilot burner** includes an ignitor and flame sense probe. The ignitor provides the spark, originating at the ignition control module, to light the pilot. The ignition control module proves and monitors the pilot flame through the flame sensing probe.

SEQUENCE OF OPERATION

All units follow the same basic sequence of operation and is as follows:

1. Thermostat calls for heat. Drafter relay energizes drafter with call for heat.
2. Ignition control module energizes pilot operator of gas valve and initiates spark at ignitor of the pilot burner.
3. Pilot burner ignition is proven to the ignition control by the flame sense probe and sparking of the ignitor is discontinued.
4. Once pilot burner operation is proven, the ignition control module energizes the main burner operator of the gas valve, allowing gas flow to the main burners. In addition, drafter operation must be proven by drafter pressure switch before ignition control module energizes main burner operator of gas valve.
5. Approximately 60 seconds after the main burners light, the fan time delay initiates fan operation.
6. Thermostat is satisfied and call for heat is removed. Drafter relay de-energizes drafter with removal of call for heat.
7. Ignition control module de-energizes pilot and main burner operators of the gas valve, ceasing all gas flow.
8. Approximately two minutes after satisfying the thermostat, fan operation ceases.

OPTIONAL GAS CONTROLS

These units are available with optional gas controls which will give either multi-stage or modulating operation. The sequence of operation of those units equipped with these optional gas controls differs only at what rate each duct furnace's main burners ignite and operate at, or the order of duct furnace firing for those units equipped with two or three duct furnaces.

Two Stage Units: Two stages of heating; first stage is 50% of full rate, second stage is 100% of full rate. Main burner ignition is at first stage only.

Three Stage Units: *Dual duct furnace models:* First furnace is equipped with two stage heating; second furnace is equipped with single stage heating but fired independently, giving three stages of heating.

Triple duct furnace models: Each duct furnace is equipped with single stage heating but fired independently, giving three stages. Each stage is 33% of the unit's full input rate. Duct furnace one will always light first and disengage last.

Four Stage Units: Dual duct furnace models only. Each duct furnace is equipped with two stage heating but fired independently, giving four stages. Each stage is 25% of the units full input rate. Duct furnace one will always light first and disengage last.

Six Stage Units: Triple duct furnace models only. Each duct furnace is equipped with two stage heating but fired independently giving six stages. Each stage is 16.5% of the units full input rate. Duct furnace one will always light first and disengage last.

Electronic Modulation Units: These units are equipped with an electronic modulating control which provides unit firing capabilities of 40 to 100% of the units full input rate. This control is found in the gas train downstream of the gas valve and allows main burner ignition only at the maximum rate. A thermostat with remote setpoint adjustment modulates the gas input.

Multi-Stage w/Electronic Modulation Units: These dual and triple duct furnace models are equipped with an electronic modulating control on duct furnace one and single or two stage heating on each successive duct furnace. Furnace one (modulated) will fire first and disengage last. Additional stages of heat will engage after furnace one has fired at maximum modulation capability for the duration of the delay setting. The amount of modulation and each stage size depends upon unit size and the number of stages. See following chart.

Number of Stages	Modulation Capabilities (% of full input)	Stage Size (% of full input)
2	25 - 50	50
3	16.5 - 33	33
4	25 - 50	25
6	16.5 - 33	16.5

AIR HANDLING REQUIREMENTS AND ADJUSTMENTS

▲ CAUTION Remove wooden shipping support from beneath blower housing of Blower Section (if applicable) to prevent possible unit damage or improper unit operation.

Static Pressure through the unit should never exceed 2.0" W.C. (0.50 kPa). Units operate at a temperature rise range of 30 to 80°F (17 to 44°C).

NOTICE: It is important that the final temperature leaving the unit does not exceed 160° F (71°C). When final air throughput adjustments are being made, a check of the discharge air temperature should be made after unit has operated for 15 to 20 minutes.

▲ CAUTION A unit should never be allowed to cycle on the primary limit for a prolonged period of time. It is a safety control to prevent a fire. If cycling on the primary limit is noted, corrective measures should be taken immediately. Failure to do so could result in unit damage or a fire.

NOTICE: At initial unit installation, unit should be started momentarily to confirm proper blower wheel rotation as the unit will deliver some air with the blower wheel running backwards.

Two basic air control systems can be used to deliver conditioned air to the occupied space: intermittent or constant fan operation.

Intermittent Fan Operation: The unit employs an air control system which utilizes a fan time delay relay to operate the fan while heating and the thermostat while cooling. Refer to unit wiring diagram.

Constant Fan Operation: The unit can be wired to give an air control system which constantly circulates air through the unit and occupied space with constant fan operation. Refer to unit wiring diagram.

NOTICE: Check blower belt tension. Proper belt tension is important to the long life of the belt and motor. Proper belt tension will allow the belt to be depressed 1/2" to 3/4".

It is important that the blower motor and the blower wheel pulleys be in good alignment, with the motor and blower shafts parallel.

Belt tension must be adjusted to give approximately 3/4" deflection of the belt when finger pressure is applied to the middle of the belt (See figure 12). Small changes in this tension may be necessary for optimum operation. Belts will stretch over a period of time, requiring an adjustment to this tension. See MAINTENANCE section for belt and pulley adjustments.

These units are set at the factory for the RPM required to meet the air volume (CFM) and external static pressure ordered. If the estimated external static is incorrect, or changes were made to the duct system, the blower RPM may need to be changed.

Both the Standard and High CFM Blowers use motors which are equipped with adjustable pitch pulleys. After removing belt(s), loosen the pulley set screw and remove the key, turn adjustable half of a pulley clockwise to increase RPM, or counter-clockwise to decrease RPM. Insert key, tighten set screw and replace belt(s). Adjust belt tension to give 1/2" to 3/4" belt play when depressed.

▲ WARNING Blower motor full load amps should never be exceeded. Improper unit operation or motor failure could result.

After changing blower RPM, confirm blower motor full load amps have not been exceeded. See motor data plate for maximum full load amps.

Figure 11

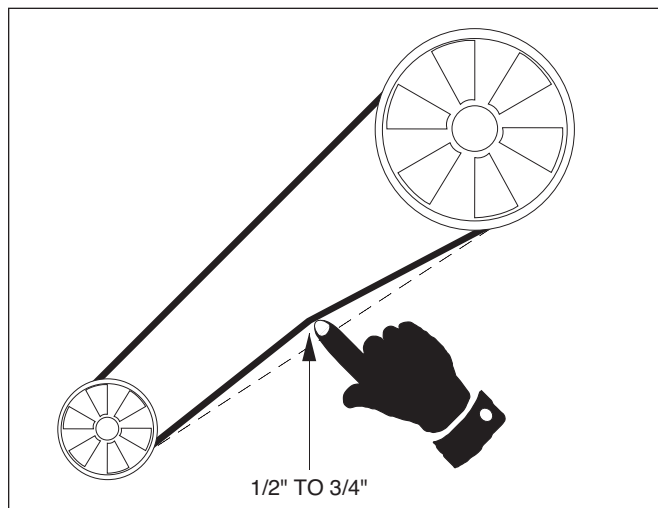

LIGHTING

(Refer to Indoor Duct Furnace Manual for all heating functions - general comments are as follows.) Purge the gas line to the unit of air before attempting to light the pilot. Check for gas leaks.

▲ WARNING Never use an open flame to detect gas leaks. Explosive conditions may exist which could result in personal injury or death.

This unit is equipped with an intermittent ignition system. A lighting instruction label is attached to the unit. To set the intermittent ignition system into operation, proceed as follows:

1. Turn on the gas valve(s) main manual valve.
2. Turn on electrical power. The unit is now under thermostat control.

3. Set thermostat to highest level. This will initiate the sequence of operation detailed in the Gas Control System section. Check main burners for operation.
4. Set thermostat to lowest level. This will interrupt power to the ignition control and shut off gas. Confirm pilot and main burners have been extinguished.
5. Set the thermostat to the desired setting.

For complete unit shutdown, proceed as follows:

1. Turn off the gas valve(s) main manual valve.
2. Set thermostat to lowest setting.
3. Shut off all electric power.

GAS INPUT ADJUSTMENT

When shipped from the factory, all units are equipped for the average heat content of the gas which is stamped on the unit rating plate.

▲ CAUTION Since the heat content of gas varies by locality, the input must be checked after installation of the unit. If the unit is overfired it will shorten the life of the heat exchanger. Never exceed the input on the rating plate.

For an accurate input rate measurement, the following meter method should be used to determine unit input rate. If the meter method is not possible, a manifold pressure check should be made.

Meter Method of Checking Input Rate

1. Obtain the heating value of the gas from the local utility or gas dealer. This should be in units of Btu/ft³ (MJ/m³).
2. Determine the gas flow rate as shown in the following example. EXAMPLE: Assume this unit has a input rate of 250,000 Btu/hr (73.2 kW) and the heating value of the gas is 1000 Btu/ft³ (37.3 MJ/m³).

$$\begin{aligned} \text{Gas Flow Rate} &= \frac{250,000 \text{ Btu/hr}}{1000 \text{ Btu/ft}^3 \times 60 \text{ min/hr}} \\ &= 4.17 \text{ ft}^3/\text{min} \end{aligned}$$

3. Before determining the gas flow rate to the unit, all other gas appliances connected to the same meter must be turned off.
4. Fire unit according to instructions.

- After approximately 15 minutes of unit operation, determine volume of gas used in five minutes of unit operation. For the Example above the unit should use 4.17 ft³/min x 5 min = 20.8 ft³ (1.97 L/s x 5 min x 60 s/min = 591L) of gas. Minor input adjustments can be made by removing pressure regulator cap and turning regulator clockwise to increase input or counter clockwise to decrease input. Any appreciable adjustment in input rate should be made by reorificing.

Method to Check Manifold Pressure

- Close the manual valve of unit gas valve.
- Install a 1/8" pipe connection in the tapped hole provided in the gas valve body near outlet of the valve.
- Attach manometer to 1/8" pipe connection by means of a rubber hose.
- Fire unit according to instructions and observe the pressure and confirm it matches the unit manifold pressure from the unit rating plate.
- Small variations in the manifold pressure can be made by means of the gas valve pressure regulator. Remove pressure regulator cap and turn regulator clockwise to increase pressure or counter-clockwise to decrease pressure.

PILOT ADJUSTMENT

- Disconnect wire from terminal marked MV at gas valve.
- Provide call for heat.
- Pilot adjustment is found on the gas valve. Remove pilot adjustment cap.
- Adjust the pilot screw to provide properly sized flame.
- A proper pilot burner flame is a soft steady flame that envelopes 3/8 to 1/2 inch (9.5 to 12.7mm) of the flame sense probe tip.
- Replace the pilot adjustment cap.
- Reconnect wire to terminal MV.

PRIMARY AIR SHUTTER ADJUSTMENT

After the unit has been in operation for at least 15 minutes, adjust the primary air flow to the burners. Turn the friction-locked manually rotated air shutters clockwise to close, counter clockwise to open. For correct air adjustment, close the air shutter until yellow tips in the flame appear. Then open the air shutter to the point just beyond the position where yellow tipping disappears.

CONTROLS

(also see the Indoor Duct Furnace Manual):

Primary Limit Control: The primary limit control is a factory installed component surface mounted in the inlet airstream at the end of the heat exchanger. When the temperature reaches the limit setpoint, normally caused by insufficient air throughput, all gas is shutoff. The limit control has an automatic reset and once the unit has cooled, it will reset itself. This is a safety control and if cycling on the primary limit is noted, corrective action must be taken. See unit wiring diagram for electrical location. This control must never be bypassed. Upon completion of unit installation, the primary limit must be checked for proper operation. This can be accomplished by removing power to the indoor air blower and a call for heat.

Clogged Filter Switch: (Optional) The clogged filter switch monitors the pressure differential across the air filters. If this pressure differential becomes too great, the switch will alert of this condition. At this point the air filters must either be cleaned or replaced. The switch will reset itself.

Firestat: (Optional) Located in either the return airstream, the supply airstream, or both, this control monitors temperatures with setpoints which are field adjustable. If the temperature exceeds the setpoint, the control will cease unit operation. To resume unit operation, a manual reset of this control is required.

Freezestat: (Optional) Located in either the return airstream, the supply airstream, or both, this control monitors temperatures with setpoints which are field adjustable. If the temperature does not exceed the setpoint, the control will cease unit operation.

V. START UP

Before starting the unit, use the "Installation Check Sheet" (located at the end of this manual) and read the Indoor Duct Furnace Manual entirely in conjunction with the procedures outlined below to ensure that the unit is completely and properly installed and ready for start up.

▲ WARNING It is the installer's responsibility to check all safety controls! Check and test the operational functions of all safety devices supplied with this unit. Failure to do so could result in unsafe conditions and may result in death, serious injury or property damage.

- Inspect all wiring connections; connections should be clean and tight. **Trace circuits to insure that actual wiring agrees with the "as wired" diagrams provided with the unit.** Information in the wiring diagram title block should match the data appearing on the unit nameplate.
- Lubricate all electrical motors according to the manufacturer's recommendations.

3. Verify that the system switch is in the OFF position.
4. Check unit supply voltage to ensure that it is within the utilization range.
5. Inspect the interior of the unit; remove any debris or tools which may be present.
3. Cycle unit on all safety controls to verify proper unit operation.
4. Confirm proper operating control (thermostat or ductstat) operation by cycling unit.
5. Secure all exterior panels in place.

Starting Unit in Heating Mode

1. Close the unit disconnect switch which provides power to the unit.

▲ WARNING High voltage is present in some areas of the unit (primarily the main electrical cabinet) with the unit disconnect switch closed. Failure to exercise caution when working in the presence of energized electrical components may result in injury or death from electrical shock.

2. Set the thermostat/switching subbase as indicated below: a. position the heating system switch at either HEAT or AUTO; b. set the fan switch to AUTO.
3. Place the system switch in the ON position. With the thermostat calling for heat, unit operation is automatic.

Starting Unit in Cooling Mode

1. Close the unit disconnect switch which provides power to the unit.

▲ WARNING High voltage is present in some areas of the unit (primarily the main electrical cabinet) with the unit disconnect switch closed. Failure to exercise caution when working in the presence of energized electrical components may result in injury or death from electrical shock.

2. Set the thermostat/switching subbase as indicated below: a. position the cooling system switch at either COOL or AUTO; b. set the fan switch to AUTO.
3. Place the system switch in the ON position.

With the thermostat calling for cooling, unit operation is automatic.

Final Checkout

Run the unit sequentially through its stages of heating and cooling. Once proper unit operation is verified, perform these final steps:

1. Inspect unit for debris and/or misplaced tools and hardware.
2. Be sure all gas valves and controls are in the operating position if the unit will be operating immediately.

VI. MAINTENANCE

	<p>▲ WARNING</p> <p>HAZARDOUS VOLTAGE! DISCONNECT ALL ELECTRIC POWER INCLUDING REMOTE DISCONNECTS BEFORE SERVICING. Failure to disconnect power before servicing can cause severe personal injury or death.</p>
--	---

▲ WARNING It is the service technician's responsibility to check all safety controls! Check and test the operational functions of all safety devices supplied with this unit. Failure to do so could result in unsafe conditions and may result in death, serious injury or property damage.

These units have been developed for indoor installation. Maintenance is required and it is suggested that the following unit servicing and inspections be performed routinely. Also read in entirety and refer to the Indoor Duct Furnace Manual for maintenance requirements.

Inspect area near unit to be sure that there is no combustible material located within the minimum clearance requirements (See Figure 5). Service panels provide easy access to the gas controls (located in duct furnace section), the blower compartment, the electrical cabinet and the supply plenum. To remove the service door from any of these compartments, refer to access panel removal section in beginning of this manual.

The pilot burner can be serviced by removing the pilot plate from the main burner drawer assembly.

The (rear) high limit safety switch is accessible by removing the exterior upper jacket, then remove the mounting plate from the side panel of the heat exchanger. This limit must have proper surface contact when reinstalled. The (front) primary safety limit is accessible by removing the mounting cover from the furnace jacket.

To remove the main burner drawer assembly (also refer to Indoor Duct Furnace Installation and Service Manual) for servicing the burners, proceed as follows:

1. Shut off the gas supply at the gas shutoff valve and electrical power to the unit.
2. Break the union upstream of duct furnace gas valve and loosen the union external to the furnace; swing downward the piping to clear drawer.
3. Disconnect duct furnace gas valve wiring taking note of all wire locations. Disconnect ignitor and flame sensing probe wires at ignition control module and any other wires.
4. Remove the locking screws holding the burner drawer assembly in position.
5. Slide the burner drawer out of the duct furnace.
6. Removal of burners is accomplished by sliding burner towards manifold, compressing locating spring, until the rear of the burner clears slot in back of burner drawer.
7. With burner drawer removed from duct furnace, inspect the inside surfaces of the heat exchanger. Wire brush if necessary.
8. Remove any dirt, dust or other foreign matter from the burners using a wire brush and/or compressed air. Insure all parts of the burner are unobstructed. Inspect and clean pilot burner if necessary.
9. Reassemble the duct furnace by replacing all parts in order.
10. Light unit per the unit lighting instructions.
11. Check the burner adjustment. See the "Primary Air Adjustment" section of this manual.
12. Check all gas control valves and pipe connections for leaks.
13. Check the operation of the duct furnace gas valve by lowering the setting of the thermostat, stopping the operation of the duct furnace. The duct furnace gas valve should close, extinguishing the pilot and main burner flames.
14. Inspect and service the blower section of the system.
15. Inspect and check the operational functions of all safety devices equipped with your unit to ensure that all devices are performing adequately.

HIGH LIMIT AND/OR SAFETY LIMIT MAINTENANCE

To service or replace high limit and/or safety limit:

1. Turnoff the manual gas valve and electrical power to the unit.
2. To service the High Limit:
 - a. Remove the Mounting Cover located on the access side of the unit toward the rear (Air Inlet) of the furnace section. Remove the mounting plate from the side panel of the heat exchanger. The mounting plate is part of the High Limit; making note of wire locations for reconnecting.
 - b. Remove all electrical connections from the High Limit; making note of wire locations for reconnecting.
 - c. Reassemble the High Limit by replacing all parts in order; making sure the High Limit is making proper surface contact when installed.
3. To service the Safety Limit:
 - a. Remove Mounting Cover located on the access side of the unit toward the front (Air Outlet) of the furnace section.
 - b. Remove all electrical connections from the Safety Limit; making note of wire locations for reconnecting.
 - c. Reassemble the Safety Limit by replacing all parts in order; making sure the Safety Limit is making proper surface contact with the side of the heat exchanger.
4. Complete appropriate start-up procedure as given in the "Start-Up" section of the MAIM manual.
5. Check Burner Adjustment.
6. Check gas control valves and pipe connection for leaks.
7. Check operation of auto gas valve.
8. Check operation of safety devices.
9. Inspect and service blower section of system.

▲ WARNING Under no circumstance should combustible material be located within the specified clearances. Failure to provide proper clearance could result in personal injury or property damage from fire.

▲ WARNING Under no circumstance should combustible material be located within the specified clearances. Failure to provide proper clearance could result in personal injury or property damage from fire.

SEASONAL MAINTENANCE

The unit should be thoroughly checked before the start and at the end of each heating and cooling season.

- A. Motors and belts should be inspected.
- B. Tighten belts if loose.
- C. Check and clean DX or Chilled Water coil twice yearly, if unit is so equipped per manufacturer's service manual. Chilled Water coil must be winterized at beginning of heating season (i.e. drain water from coil per manufacturer's instructions).
- D. Check air throughput at beginning of heating season to confirm unit operation is within the specified temperature rise range.
- E. At beginning of heating season clear Condensate Drain Pan and P-trap of water if unit is equipped with DX or Chilled water coil. Clean out drain pan and fill P-trap with a non-toxic glycol solution.
- F. Evaporative cooler must be cleaned and maintained per manufacturer's instruction frequently during the operating season.
- G. Inspect Control Dampers during periodic maintenance. Damper pivot points should be cleaned to ensure free damper operation.
- H. Blower wheels should be checked periodically for dirt build-up on blades. Clean as required.

FILTERS

The filter section has been designed to incorporate (as standard) one-inch washable filters. Other optional filter types are also available: two-inch washable throwaways; or one or two inch hi-efficiency 30% pleated filters.

It is recommended that air filters be changed or cleaned at least four times a year. More frequent attention to filters is required if the air being handled by the unit is unusually dirty. Air flow reduction, caused by the dirty air filters, will increase the discharge air temperature and may cause unit cycling on the primary limit.

Filters (by others) should be serviced regularly and changed or washed when necessary to maintain the required air throughput. In a dusty environment, filters may clog up in less than one month.

Standard CFM Blower Air Filter Size Requirements

Unit Input	Number of Filters Required	
	16 x 20 (in)	20 x 20 (in)
100 MBH (29.3 kW)	4	
150 MBH (44.0 kW)	4	
200 MBH (58.6 kW)		4
250 MBH (73.2 kW)		4
300 MBH (87.9 kW)	4	2
350 MBH (102.6 kW)	4	2
400 MBH (117.2 kW)		6
500 MBH (146.5 kW)		4
600 MBM (175.8 kW)	4	2
700 MBM (205.1 kW)	4	2
800 MBH (234.4 kW)		6

High CFM Blower Air Filter Size Requirements

Unit Input	Number of Filters Required	
	16 x 20 (in)	20 x 20 (in)
100 MBH (29.3 kW)	8	
150 MBH (44.0 kW)	8	
200 MBH (58.6 kW)		8
250 MBH (73.2 kW)		8
300 MBH (87.9 kW)	8	4
350 MBH (102.6 kW)	8	4
400 MBH (117.2 kW)		12
500 MBH (146.5 kW)		8
600 MBH (175.8 kW)	8	4
700 MBH (205.1 kW)	8	4
800 MBH (234.4 kW)		12
1,200 MBH (351.6kW)		12

Figure 12

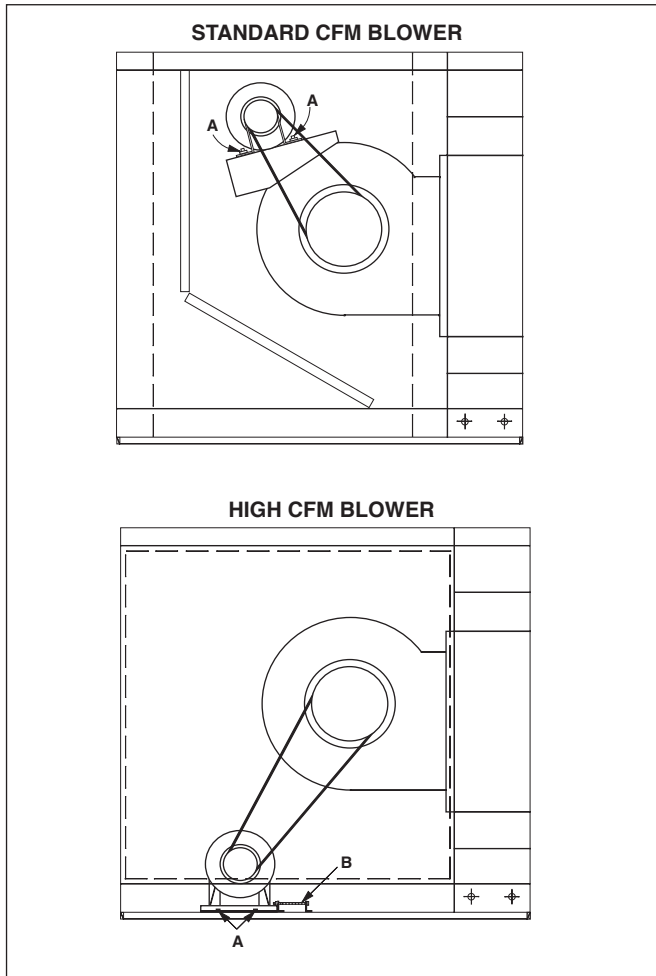

AIR BLOWER

Belt Tension Adjustment Standard CFM Blower belt tension can be adjusted by loosening motor mounting bolts marked A (See Figure 12). To tighten belt, slide motor down motor mounting bracket and re-fasten motor to mounting bracket.

High CFM Blower belt(s) tension can be adjusted by first loosening motor mounting plate bolts marked A (See Figure 12). To tighten belt tension, turn belt tension adjustment screws marked B (See Figure 12) counter-clockwise. To loosen belt tension, turn clockwise. Once belt tension has been adjusted, re-fasten motor mounting plate bolts.

Blower RPM Adjustment

To adjust blower RPM:

1. Loosen and remove belt(s).
2. Match driver pulley to one found in Figure 13.
3. Loosen set screw(s) marked A.
4. If driver pulley is equipped with external key, marked B, remove.
5. Adjust driver pulley pitch diameter for desired speed by opening (slower) or closing (faster) moving parts by half or full turns. Do not open sheave past point where flange projects past the hub end.
6. If driver pulley is equipped with external key, marked B, replace.
7. Tighten set screw(s) marked A.
8. Replace and retension belt(s).
9. Realign drive if necessary.

Figure 13

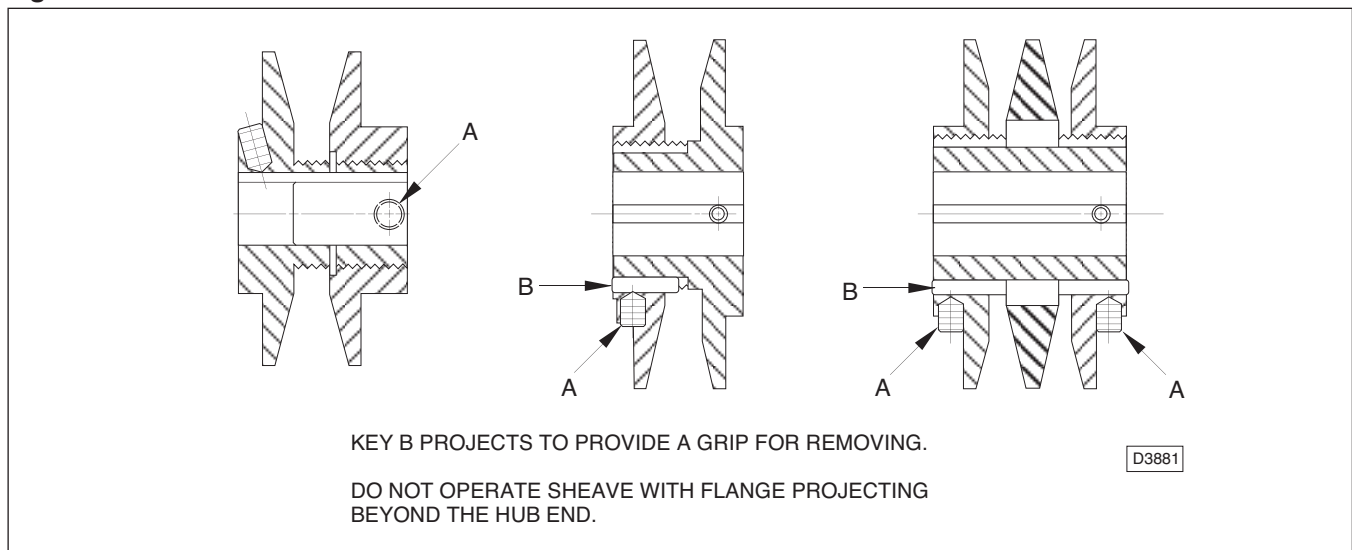

VII. TROUBLESHOOTING

For troubleshooting of the duct furnace, refer to the Indoor Gas-Fired Duct Furnace Installation and Service Manual. For Evaporative Cooler/Cooling Coil equipped units, refer to these specific manuals for additional troubleshooting guides.

For additional troubleshooting, see following Troubleshooting Guide.

TRoubleshooting Guide AIR BLOWER

PROBLEM	PROBABLE CAUSE	SOLUTION
1. Noise	Blower Wheel Hitting Scroll Side	<ul style="list-style-type: none"> a. Blower Wheel not centered in blower housing. b. Damaged blower housing. c. Damaged blower wheel. d. Shaft loose in blower bearing. e. Blower Wheel loose on shaft. f. Blower bearing loose in bearing support.
	Blower Wheel Hitting Cutoff	<ul style="list-style-type: none"> a. Cutoff not secure in blower housing. b. Cutoff damaged. c. Cutoff improperly positioned.
	Drive	<ul style="list-style-type: none"> a. Pulley not tight on shaft (motor and/or blower wheel). b. Belts too loose. Adjust for belt stretching after 48 hours of operation. c. Belts too tight. d. Belts wrong cross section. e. Belts not matched in length on multi-belt drive. f. Variable pitch pulleys not adjusted so each pulley has same pitch diameter (multi-belt drives). g. Misaligned pulleys. h. Belts worn. i. Motor or motor base loose. j. Belts oily or dirty. k. Improper drive selection.
	Bearing	<ul style="list-style-type: none"> a. Defective bearing. b. Needs lubrication. c. Loose on bearing support. d. Loose on shaft. e. Seals misaligned. f. Foreign material in bearing. g. Worn bearing. h. Fretting corrosion between inner race and shaft.
	Shaft Seal Squeal	<ul style="list-style-type: none"> a. Needs lubrication. b. Misaligned.

PROBLEM	PROBABLE CAUSE	SOLUTION	
1. Noise	Blower Wheel	<ul style="list-style-type: none"> a. Loose on shaft. b. Defective blower wheel. Do not run blower. Contact manufacturer. c. Unbalanced. d. Worn as a result of contact with abrasive or corrosive material. 	
	Housing	<ul style="list-style-type: none"> a. Foreign material in housing. b. Cutoff of other part loose (rattling during operation). 	
	Electrical	<ul style="list-style-type: none"> a. Lead-in cable not secure. b. AC hum in motor or relay. c. Starting relay chatter. d. Noisy motor bearings. e. Single phasing a 3 phase motor. 	
	Shaft	<ul style="list-style-type: none"> a. Bent. b. Undersized. May cause noise at blower wheel, bearings or pulley. c. If more than two bearings are on a shaft, they must be properly aligned. 	
	High Air Velocity	<ul style="list-style-type: none"> a. Duct work too small for application. b. Blower selection too small for application. c. Registers or grilles too small for application. d. Cooling coil with insufficient face area for application. 	
	Obstruction in High Velocity Air Stream may cause Rattle or Pure Tone Whistle	<ul style="list-style-type: none"> a. Dampers. b. Registers. c. Grilles. d. Sharp elbows. e. Sudden expansion in duct work. f. Sudden contraction in duct work. g. Turning vanes. 	
	Pulsation or Surge	<ul style="list-style-type: none"> a. Blower too large for application. b. Ducts vibrate at same frequency as blower pulsations. 	
	Rattles and/or Rumbles	<ul style="list-style-type: none"> a. Vibrating duct work. b. Vibrating cabinet parts. c. Vibrating parts not isolated from building. 	
	2. CFM Low - Insufficient Air Flow	Blower	<ul style="list-style-type: none"> a. Forward curved blower wheel installed backwards. b. Blower operating backwards. c. Cutoff missing or improperly installed. d. Blower wheel RPM too low.
		Duct System	<ul style="list-style-type: none"> a. Actual system is more restrictive than expected. b. Dampers closed. c. Registers closed. d. Leaks in supply duct.

PROBLEM	PROBABLE CAUSE	SOLUTION
2. CFM Low Insufficient Air Flow	Filters	Dirty or clogged.
	Coil - DX or Chilled Water	Dirty or clogged.
	Obstructions in High Velocity Air Stream	a. Obstruction near unit outlet. b. Sharp elbows near unit outlet. c. Improperly designed turning vanes. d. Projections, dampers or other obstructions in part of duct system where air velocity is high.
3. CFM High - Too Much Air Flow	System	a. Oversized duct work. b. Access door open. c. Registers or grilles not installed. d. Filters not in place. e. System resistance lower than anticipated.
	Blower	Blower RPM is too great.
4. Blower Does Not Operate	Installation	a. Incorrect electrical connection. b. Wrong voltage. c. Blown fuse.
	Unit	a. Broken belt(s). b. Loose pulleys. c. Power to unit is disconnected. d. Motor overload protector has broken circuit. e. Optional thermostats, firestats, freezestats may lockout blower operation if set incorrect.

TROUBLESHOOTING GUIDE ELECTRIC MOTORS

PROBLEM	PROBABLE CAUSE	SOLUTION
1. Motor	Blown fuse or open circuit breaker.	Replace fuse or reset circuit breaker.
	Overload trip.	Check and reset, if manual.
	Improper line connections.	Check connections to unit wiring diagram.
	Improper current supply.	Check to determine that power supply agrees with motor nameplate specifications.
	Mechanical failure.	Determine that motor and drive turn freely. Check bearings.
	Motor overloaded.	Reduce load or replace motor.
	With a 3 phase power source, one phase may be open.	Check line for open phase.
	Defective capacitor.	Replace capacitor.
2. Motor Stalls	Wrong application.	Consult manufacturer.
	Overloaded motor.	Reduce load or replace motor.
	Low line voltage.	Check across AC line and correct if possible.

PROBLEM	PROBABLE CAUSE	SOLUTION
3. Motor runs and then dies down.	Partial loss of line voltage.	Check for loose connections. Determine adequacy of main power supply.
4. Motor does not come up to speed.	Motor undersized for application.	Replace with larger motor.
	Voltage too low at motor terminals.	Check across AC line and correct if possible.
	Line wiring to motor is too small.	Install larger line wiring.
5. Motor takes too long to accelerate.	Excessive load.	Replace with larger motor.
	Loose connection.	Check connections and tighten where necessary.
6. Wrong Rotation (3 Phase)	Improperly wired to AC line (wrong sequence of phases).	Check unit wiring diagram. Reverse any two line voltage connections.
7. Motor Overheats	Motor overloaded.	Replace with larger motor.
	Motor ventilation clogged.	Clean motor.
	Motor (3 phase) may have open phase.	Check to insure that all connections are tight.
	Line voltage too high or too low.	Check across AC line and correct if possible.
	Worn blower bearings.	Replace blower bearings.
8. Motor Vibrates	Motor mounting bolts loose.	Tighten mounting bolts.
	Driven equipment unbalanced.	Balance driven equipment.
	Worn motor bearings.	Replace motor.
	3 phase Motor running on single phase.	Check for open circuit and correct.
	Bent motor shaft.	Replace motor.
9. Rapid Motor Bearing Wear	Excessive overhung load due to over tensioned belt.	Reduce belt tension.

TROUBLESHOOTING GUIDE FAN ASSEMBLY

PROBLEM	PROBABLE CAUSE	SOLUTION
1. Short Belt Life	Spin burns from belt slippage.	Tension belt.
	High ambient temperature.	Use Gripnotch belts.
	Grease or oil on belts.	Clean belts and pulleys.
	Worn pulleys.	Replace pulleys.
	Belt Misalignment.	Realign drive.
2. Belts turn over in grooves	Damaged belt.	Replace belt.
	Excessive vibration.	Tension belts. Replace belts if damaged.
	Worn pulleys.	Replace pulleys.
	Pulley Misalignment.	Realign drive.
3. Belt Squeal	Excessive load.	High starting load. Retension drive.
4. Belt Breakage	Foreign material in drive.	Provide drive guard.
	Belts damaged during installation.	Replace belts.
	Extreme Overload.	Eliminate overload.
5. Excessive Vibration	Damaged belt cord section.	Replace belts.
	Loose belts.	Tension drive.
	Belts improperly tensioned.	Tension drive with slack of each belt on the same side of drive.

PROBLEM	PROBABLE CAUSE	SOLUTION
6. Belts mismatched after service	Belts improperly tensioned, causing more stretch of some belts than others.	Replace belts and tension drive with slack of each belt on the same side of the drive.
	Old belts and new belts used on same drive.	Replace with new belts.
	Different brand name belts used on same drive.	Replace with a set of Machine Matched Belts.
	Driver and driven shafts shifted from parallel.	Realign drive.
	Belt cord section damaged during installation.	Replace belts and install properly.
7. Drive fails to adjust	Fretting corrosion (drive allowed to operate at one speed over a period of time).	Driver pulley must be disassembled, cleaned and lubricated, then reassembled.

TROUBLESHOOTING GUIDE DX COOLING COIL

PROBLEM	PROBABLE CAUSE	SOLUTION
1. No or Insufficient Cooling	Coil icing.	a. Low liquid line pressure.*
		b. Thermal expansion valve.**
		c. Low air flow across coil.
	Air binding.	Purge and charge system.
	Thermal expansion valve.**	a. Bulb mounted at incorrect location.
		b. Bulb not secured properly.
	Insufficient air flow.	a. See air blower troubleshooting.
		b. Clogged coil
	Air bypassing coil.	Caulk safe off.
	Undersized system, demand exceeding cooling system capacity.	Replace system.*
Too much outside air.	Check outside air dampers.	
Refrigerant leak.	Determine leak location and correct.	
Low liquid pressure.	Determine cause and correct.*	
2. Water in Conditioned Air	Exceeding coil face velocity - 600 fpm.	Reduce unit air flow.
	Drain pan p-trap clogged.	Clean pan and p-trap.

* Refer to condensing unit installation and service manual.

**Refer to thermal expansion valve installation instruction.

TROUBLESHOOTING GUIDE CHILLED WATER COOLING COIL

PROBLEM	PROBABLE CAUSE	SOLUTION
1. No or Insufficient Cooling	Circulating pump failure.	Repair or replace pump.*
	Chilled water temperature not cool enough.	Check chiller.*
	Air binding (air in coil).	Bleed coil.
	Insufficient chilled water flow.	a. Circulating pump capacity is inadequate.* b. System piping losses too great.
	Insufficient air flow.	a. See air blower troubleshooting. b. Clogged coil
	Air bypassing coil.	Caulk safe off.
	Undersized system, demand exceeding cooling system capacity.	Replace system.*
	Too much outside air.	Check outside air dampers.
2. Water in Conditioned Air	Exceeding coil face velocity - 600 fpm.	Reduce unit air flow.
	Drain pan P-trap clogged.	Clean pan and p-trap.

*Refer to Manufacturer's Installation and Service Manual.

VIII. REPLACEMENT PARTS

To order Replacement Parts, please provide the following information to your local representative:

- Model Number
- Serial Number
- Part description and Number as shown in Replacement Parts Literature

If further assistance is required, please contact the manufacturer's customer service department

IX. SERVICE NOTE

Due to the many configurations, options and voltage characteristics available on Make-Up Air Packaged Units, the information provided in this manual is somewhat general in context. Should user or service organization incur a problem, the nature of which is not herein, we urge you to contact the manufacturer. It would be of great assistance to us if you can provide the model and serial numbers and the wiring diagram number, as well as the access type.

X. LIMITED WARRANTY

All components are warranted by the manufacturer to be free from defects in material and workmanship for period of one (1) year from the date of shipment from the manufacturing plant.

The manufacturer will repair or replace, at its option, any component which, upon inspection, it finds to be defective, provided that the Make-Up Air Packaged Unit has been operated within its listed capacity, has been installed in accordance with all furnished instruction, has not been misused or subjected to neglect and has received reasonable and necessary maintenance. This warranty does not cover labor costs or other costs incurred in repairing, removing, installing, servicing or handling of parts or completed products.

This Warranty does not cover loss due to corrosion by chemicals precipitated in the air such as halogenated hydrocarbons. The manufacturer will in no event be liable for incidental or consequential damages of any kind whatsoever.

Written permission is required prior to the return of defective components. All returns must be sent with all transportation charges prepaid to the plant designated in the written permission. This warranty is extended only to the original owner of the Make-Up Air Package Unit.

“FOR CANADIAN INSTALLATIONS ONLY”

The following instructions apply to Canadian installations in addition to installation and operating instruction:

1. Installation must conform with local building codes, or in absence of local codes, with current CGA B149.1, Installation Codes for Natural Gas Burning Appliances and Equipment, or CGA B149.2, Installation Codes for Propane Gas Burning Appliances and Equipment.
2. Any reference to U.S. standards or codes in these instructions are to be ignored and the applicable Canadian standards or codes applied.
3. Any references to deration at altitudes in excess of 2000 feet are to be ignored. When installed in Canada at altitudes of 2000 to 4500 feet, the unit heaters must be orificed to 90% of the normal altitude rating, and be so marked in accordance with the C.G.A. certification.
4. Duct furnaces are designed certified to comply with CGA 2.6.
5. In Canada, installation is suitable in airplane hangars when acceptable to the enforcing authorities, and in public garages when installed in accordance with current CGA B149 Installation Codes for Gas Burning Appliances and Equipment.
6. All electrical connections must be in accordance with Canadian Electrical Code, Part 1, CSA Standard C22.1.
7. Canadian units include vent cap and a reducer/increaser (if required) furnished by the manufacturer.
8. In Canada, the vent system must be adequately supported to prevent sagging; but in no case shall the supports be less than every 3 feet.
9. If using a metal vent system under positive gauge pressure in Canada, a slip fit vent connection must be secured by a least two corrosive resistant screws, or other mechanical locking means.
10. Canadian units require the following vent equivalent lengths; 5 feet minimum; 50 feet maximum.
11. The vent shall not terminate —
 - a. Less than 6 feet from a combustion air inlet of another appliance.
 - b. Less than 3 feet from any other building opening or any gas service regulator.
 - c. Directly above a gas utility meter or service regulator.
12. Vent terminal shall be located not less than one foot above grade.
13. It is recommended that the heater and vent system be checked once a year by a qualified serviceman.

XI. DIMENSIONAL DATA — ARRANGEMENTS

Table #T4088-B, D

CAPACITY	A	B	F†	G	J	L	U	V Dia.**
10	32-7/8	15-9/16	16-3/8	31-1/16	24	77-3/8	73-5/8	4
	(835)	(395)	(416)	(789)	(610)	(1965)	(1870)	(102)
15	32-7/8	18-5/16	20-1/2	31-1/16	24	77-3/8	73-5/8	4
	(835)	(465)	(521)	(789)	(610)	(1965)	(1870)	(102)
20	43-7/8	23-13/16	23-1/2	42-1/16	35	77-3/8	73-5/8	5
	(1114)	(605)	(597)	(1068)	(889)	(1965)	(1870)	(127)
25	43-7/8	29-5/16	31-1/2	42-1/16	35	77-3/8	73-5/8	5
	(1114)	(745)	(800)	(1068)	(889)	(1965)	(1870)	(127)
30	54-7/8	34-13/16	34-1/4	53-1/16	46	77-3/8	73-5/8	6
	(1394)	(884)	(870)	(1348)	(1168)	(1965)	(1870)	(152)
35	54-7/8	40-5/16	42-1/4	53-1/16	46	77-3/8	73-5/8	6
	(1394)	(1024)	(1073)	(1348)	(1168)	(1965)	(1870)	(152)
40	60-3/8	45-13/16	48	58-9/16	51-1/2	77-3/8	73-5/8	6
	(1534)	(1164)	(1219)	(1487)	(1308)	(1965)	(1870)	(152)
50	43-7/8	29-5/16	31-1/2	42-1/16	35	103 3/8	99-5/8	5
	(1114)	(745)	(800)	(1068)	(889)	(2626)	(2530)	(127)
60	54-7/8	34-13/16	34-1/4	53-1/16	46	103 3/8	99-5/8	6
	(1394)	(884)	(870)	(1348)	(1168)	(2626)	(2530)	(152)
70	54-7/8	40-5/16	42-1/4	53-1/16	46	103-3/8	99-5/8	6
	(1394)	(1024)	(1073)	(1348)	(1168)	(2626)	(2530)	(152)
80	60-3/8	45-13/16	48	58-9/16	51-1/2	103-3/8	99-5/8	6
	(1534)	(1164)	(1219)	(1487)	(1308)	(2626)	(2530)	(152)

NOTES:

Dimensions are in inches (Dimensions in parenthesis are in millimeters)

* These dimensions are outside damper measurements.

† “F” Dimension is the recommended clearance to service the burner drawer.

“J” is an outside dimension for return air dampers.

**“V” Dia. = Flue Opening (ME - Power Vent Units Only); the 4” to 5” reducer adaptor is to be field supplied/installed for unit capacities 10 & 15.

The 5” to 6” increaser adaptor is supplied by the manufacturer for unit capacities 30, 35, 40, 60, 70, & 80 (required for each furnace’s flue).

Gas Inlet sizes: Natural Gas: Capacities 10 thru 20 = 1/2”; Capacities 25 thru 80 = 3/4”.

LP Gas: Capacities 10 thru 20 = 1/2”; Capacities 25 thru 80 = 1/2” or 3/4”.

All dimensional drawings for the “B” and “D” Indoor Arrangement are shown as Dual Furnace Unit Capacities (50/80). The dimensional data for Single Furnace Capacities (10/40) are tabulated in Table #T4088-B,D and Table #T4088K/T4089G accordingly for all capacities.

DIMENSIONAL DATA — ARRANGEMENTS

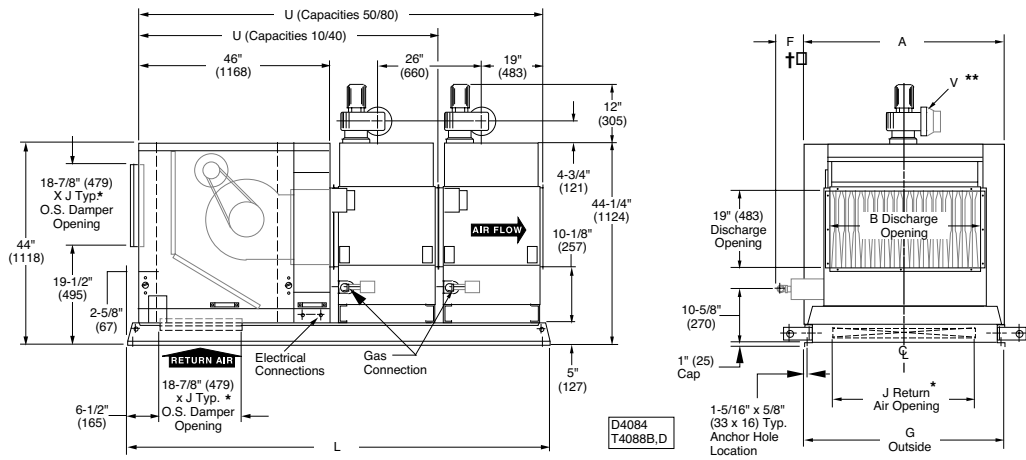

Unit Type [UT] "ME", Capacities [CA] 10 - 80, Indoor Arrangement [IA] "B"

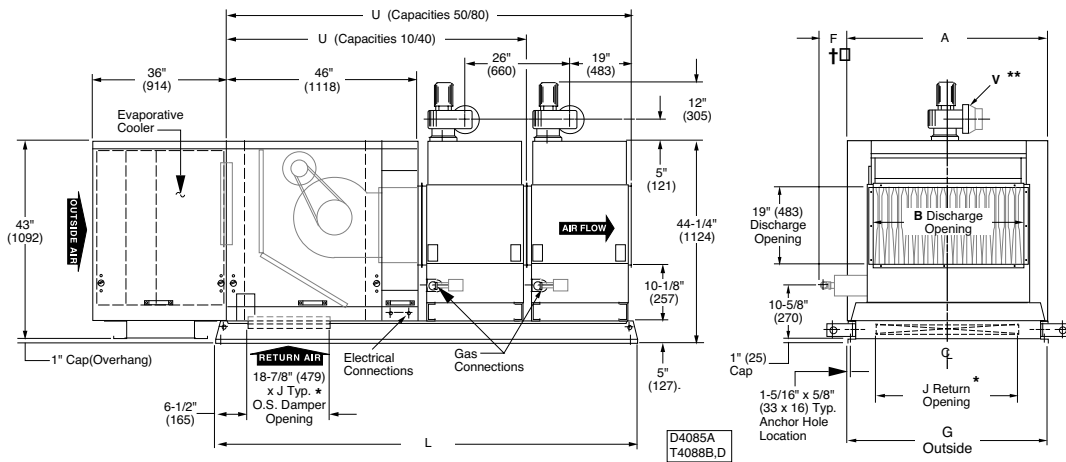

Unit Type [UT] "ME", Capacities [CA] 10 - 80, Indoor Arrangement [IA] "D"

* These Dimensions are Outside Damper Measurements.

** These Units Are Supplied With A (5" To 6") Increaser (Required For Each Furnace's Flue).

† Recommended Service Drawer Clearance.

For tabulated dimensions, see table T4088-B, D.

DIMENSIONAL DATA — ARRANGEMENTS

Table #T4088K/T4089G

CAPACITY	A	B	F	G	J	L	M	Q	R	Arr G U	Arr K U	V Dia.**
10	32-7/8 (835)	15-9/16 (395)	16-3/8 (416)	31-1/16 (789)	24 (610)	113-1/2 (2883)	21-1/4 (540)	60-5/16 (1532)	26-5/8 (676)	108-1/2 (2756)	134-1/2 (3416)	4 (102)
15	32-7/8 (835)	18-5/16 (465)	20-1/2 (521)	31-1/16 (789)	24 (610)	113-1/2 (2883)	20-1/4 (514)	60-5/16 (1532)	26-5/8 (676)	108-1/2 (2756)	134-1/2 (3416)	4 (102)
20	43-7/8 (1114)	23-13/16 (605)	23-1/2 (597)	42-1/16 (1068)	35 (889)	113-1/2 (2883)	20-1/4 (514)	60- /16 (1532)	26-5/8 (676)	108-1/2 (2756)	134-1/2 (3416)	5 (127)
25	43-7/8 (1114)	29-5/16 (745)	31-1/2 (800)	42-1/16 (1068)	35 (889)	113-1/2 (2883)	20-1/4 (514)	60-5/16 (1532)	26-5/8 (676)	108-1/2 (2756)	134-1/2 (3416)	5 (127)
30	54-7/8 (1394)	34-13/16 (884)	34-1/4 (870)	53-1/16 (1348)	46 (1168)	113-1/2 (2883)	20-1/4 (514)	60-5/16 (1532)	26-5/8 (676)	108-1/2 (2756)	134-1/2 (3416)	6 (152)
35	54-7/8 (1394)	40-5/16 (1024)	42-1/4 (1073)	53-1/16 (1348)	46 (1168)	113-1/2 (2883)	20-1/4 (514)	60-5/16 (1532)	26-5/8 (676)	108-1/2 (2756)	134-1/2 (3416)	6 (152)
40	60-3/8 (1534)	45-13/16 (1164)	48 (1219)	58-9/16 (1487)	51-1/2 (1308)	113-1/2 (2883)	21-1/4 (540)	60-5/16 (1532)	26-5/8 (676)	108-1/2 (2756)	134-1/2 (3416)	6 (152)
50	43-7/8 (1114)	29-5/16 (745)	31-1/2 (800)	42-1/16 (1068)	35 (889)	139-1/2 (3543)	20-1/4 (514)	60-13/16 (1545)	35-1/8 (892)	134-1/2 (3416)	160-1/2 (4077)	5 (127)
60	54-7/8 (1394)	34-13/16 (884)	34-1/4 (870)	53-1/16 (1348)	46 (1168)	139-1/2 (3543)	20-1/4 (514)	60-13/16 (1545)	35-1/8 (892)	134-1/2 (3416)	160-1/2 (4077)	6 (152)
70	54-7/8 (1394)	40-5/16 (1024)	42-1/4 (1073)	53-1/16 (1348)	46 (1168)	139-1/2 (3543)	20-1/4 (514)	60-13/16 (1545)	35-1/8 (892)	134-1/2 (3416)	160-1/2 (4077)	6 (152)
80	60-3/8 (1534)	45-13/16 (1164)	48 (1219)	58-9/16 (1487)	51-1/2 (1308)	139-1/2 (3543)	21-1/4 (540)	60-13/16 (1545)	35-1/8 (892)	134-1/2 (3416)	160-1/2 (4077)	6 (152)
12	60-3/8 (1534)	45-13/16 (1164)	48 (1219)	58-9/16 (1487)	51-1/2 (1308)	165-1/2 (4204)	21-1/4 (540)	86-1/8 (2188)	35-1/8 (892)	160-1/2 (4077)	186-1/2 (4737)	6 (152)

NOTES:

The dimensional data is tabulated for single and dual furnace capacities accordingly.

Using table 7 (#T4088K/T4089G), Capacities 10 & 15 apply only to Arrangement "K"; Capacity 12 applies only to Arrangement "G".

Dimensions are in inches (Dimensions in parenthesis are in millimeters).

* These dimensions are outside damper measurements.

† "F" Dimension is the recommended clearance to service the burner drawer.

"J" is an outside dimension for return air dampers.

** "V" Dia. =Flue Opening (ME - Power Vent Units Only); the 4" to 5" reducer adaptor is to field installed for unit capacities 10 & 15.

The 5" to 6" increaser adaptor is supplied by the manufacturer for unit capacities 30, 35, 40, 60, 70, 80 & 12 (required for each furnace's flue).

Gas Inlet sizes: Natural Gas: Capacities 10 thru 20 = 1/2"; Capacities 25 thru 12 = 3/4".

LP Gas: Capacities 10 thru 20 = 1/2"; Capacities 25 thru 12 = 1/2" or 3/4".

DIMENSIONAL DATA — ARRANGEMENTS

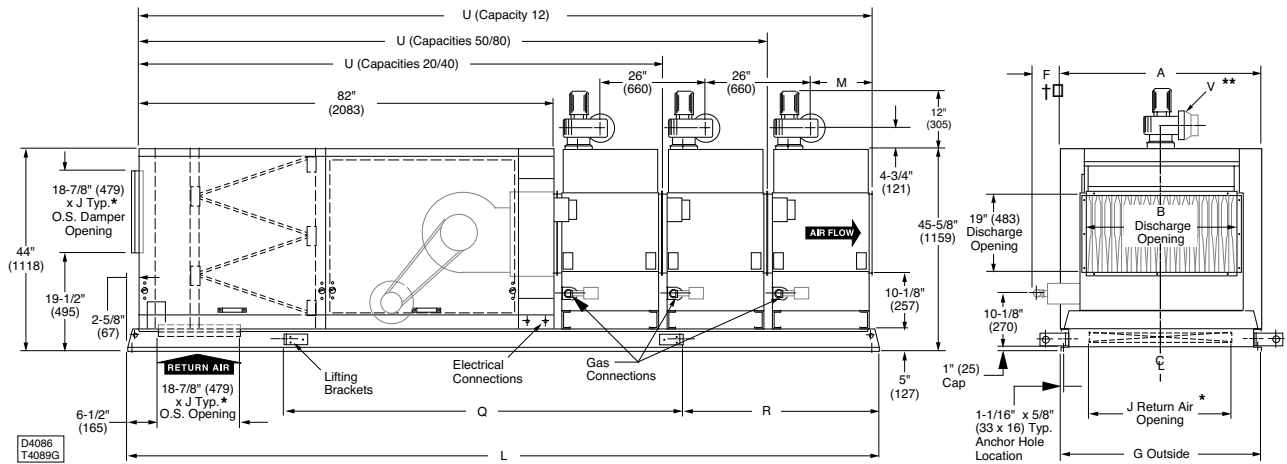

Unit Type [UT] “ME”, Capacities [CA] 20 - 12, Indoor Arrangement [IA] “G”

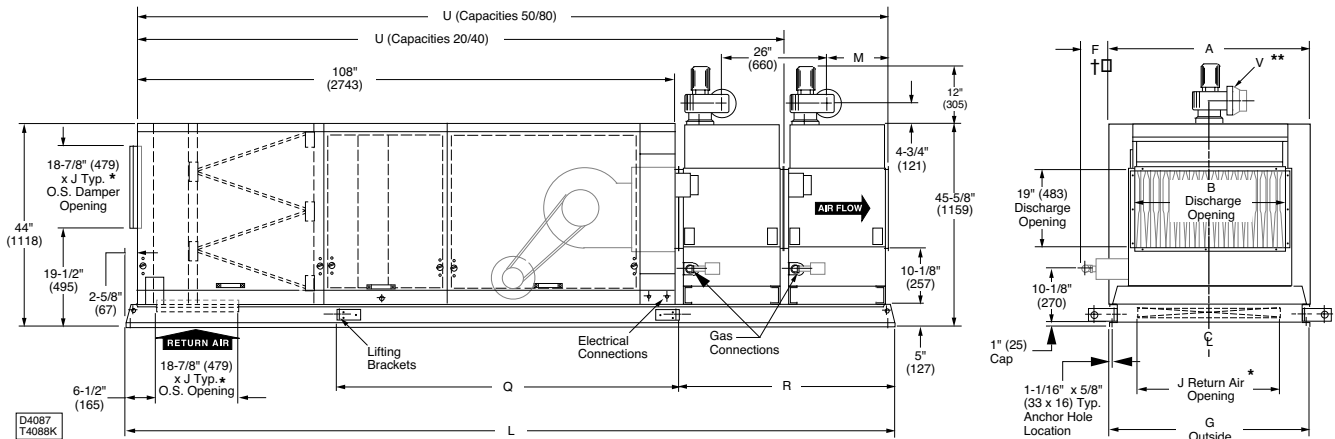

Unit Type [UT] “ME”, Capacities [CA] 10 - 80, Indoor Arrangement [IA] “K”

* These Dimensions are Outside Damper Measurements.

** These Units Are Supplied With A (5" To 6") Increaser (Required For Each Furnace's Flue).

† Recommended Service Drawer Clearance.

For tabulated dimensions, see table T4088K/T4089G.

XII. MOTOR ELECTRICAL DATA

Full Load Current In Amperes

	1 - (115/1/60)				2 - (208/1/60)				3 - (230/1/60)			
	1	2	3	4	1	2	3	4	1	2	3	4
	ODP	TE	PEODP	PETE	ODP	TE	PEODP	PETE	ODP	TE	PEODP	PETE
1/2 HP	7.2	8.6	4.6	4.6	3.7		2.8		3.8	4.3	2.3	2.3
3/4 HP	11.6	11.0	6.5	6.3	5.2	5.4	3.4		5.0	5.5	3.3	3.2
1 HP	13.0	13.4	8.6	8.5	6.6	6.8			6.5	6.7	4.3	4.3
1-1/2 HP	18.2	18.0	12.5	12.6	9.1	8.4			9.1	8.0	6.3	6.3
2 HP	21.0	23.0	17.6	17.6	11.3	11.5			10.5	8.1	8.8	8.8
3 HP	33.5	28.0			17.4	14.6			16.8	14.0		11.8
5 HP					23.5				21.0	23.0	19.1	
7-1/2 HP					33.0	31.0			31.0	29.0		
10 HP										38.0		
15 HP												
	4 - (208/3/60)				5 - (230/3/60)				6 - (460/3/60)			
	1	2	3	4	1	2	3	4	1	2	3	4
	ODP	TE	PEODP	PETE	ODP	TE	PEODP	PETE	ODP	TE	PEODP	PETE
1/2 HP	2.3	2.0	1.8	1.7	2.2	2.5	1.8	2.0	1.1	1.0	0.9	1.0
3/4 HP	3.0	3.2	2.5		3.4	3.0	2.4	2.8	1.7	1.5	1.2	1.4
1 HP	3.4	3.7	3.1	3.1	3.4	3.4	3.0	3.1	1.7	1.7	1.5	1.5
1-1/2 HP	5.1	5.0	4.5	4.5	5.2	4.6	4.4	4.4	2.6	2.3	2.2	2.2
2 HP	6.2		5.8	6.0	6.0		5.8	5.8	3.0		2.9	2.9
3 HP	9.2		8.5	9.0	8.6		8.4	8.4	4.3		4.2	4.2
5 HP			12.8	11.8			12.0	11.8			6.0	5.9
7-1/2 HP			20.4	21.0			19.4	18.8			9.7	9.4
10 HP			26.0	27.0			25.0	25.0			12.5	12.5
15 HP			37.4	38.9			35.4	37.0			17.7	18.5
	7 - (575/3/60)											
	1	2	3	4								
	ODP	TE	PEODP	PETE								
1/2 HP	0.8	0.8										
3/4 HP	1.1	1.1										
1 HP	1.3	1.7	1.2	1.2								
1-1/2 HP			1.8	1.8								
2 HP			2.3	2.4								
3 HP			3.4	3.2								
5 HP			5.3	5.3								
7-1/2 HP			7.8	7.6								
10 HP			10.0	9.6								
15 HP			14.1	15.1								

Motor Type (MT) Legend:
 ODP - Open Drip Proof
 TE - Totally Enclosed
 PEODP - Premium Efficiency Open Drip Proof
 PETE - Premium Efficiency Totally Enclosed

XIII. UNIT/SHIP WEIGHTS

Motor Shipping Weight (lbs) - Approximate

	1 - (115/1/60)				2 - (208/1/60)				3 - (230/1/60)			
	1	2	3	4	1	2	3	4	1	2	3	4
	ODP	TE	PEODP	PETE	ODP	TE	PEODP	PETE	ODP	TE	PEODP	PETE
1/2 HP	20	21	29	30	21		29		21	21	29	30
3/4 HP	23	31	38	41	23	31	38		23	31	38	41
1 HP	32	32	40	44	32	32			32	32	40	44
1-1/2 HP	35	48	47	57	35	48			35	48	47	57
2 HP	42	67	65	64	43	67			42	48	65	64
3 HP	78	72			78	72			78	72		90
5 HP					87				87	99	95	
7-1/2 HP					134	138			134	138		
10 HP										161		
15 HP												
	4 - (208/3/60)				5 - (230/3/60)				6 - (460/3/60)			
	1	2	3	4	1	2	3	4	1	2	3	4
	ODP	TE	PEODP	PETE	ODP	TE	PEODP	PETE	ODP	TE	PEODP	PETE
1/2 HP	20	22	22	22	20	22	22	22	20	22	22	22
3/4 HP	27	26	27		27	26	27	31	27	26	27	31
1 HP	24	26	36	37	24	26	36	37	24	26	36	37
1-1/2 HP	31	34	40	42	31	34	40	42	31	34	40	42
2 HP	39		46	49	39		46	49	39		46	49
3 HP	47		69	69	47		69	69	47		69	69
5 HP			76	77			76	77			76	77
7-1/2 HP			117	136			117	136			117	136
10 HP			128	158			128	158			128	158
15 HP			217	255			217	255			217	255
	7 - (575/3/60)											
	1	2	3	4								
	ODP	TE	PEODP	PETE								
1/2 HP	22	22										
3/4 HP	20	22										
1 HP	28	27	33	38								
1-1/2 HP			40	42								
2 HP			46	48								
3 HP			66	100								
5 HP			74	91								
7-1/2 HP			114	143								
10 HP			145	153								
15 HP			234	348								

Motor Type (MT) Legend:

- ODP - Open Drip Proof
- TE - Totally Enclosed
- PEODP - Premium Efficiency Open Drip Proof
- PETE - Premium Efficiency Totally Enclosed

Cooling Coil Weight Adder (Approximate)

(CA) Capacity	DX COIL	
	4 Row	6 Row
10, 15	70 lbs.	95 lbs.
20, 25, 50	95 lbs.	130 lbs.
30, 35, 60, 70	119 lbs.	166 lbs.
40, 80	130 lbs.	182 lbs.
(CA) Capacity	CHILLED WATER COIL	
	4 Row	6 Row
10, 15	170 lbs.	222 lbs.
20, 25, 50	215 lbs.	287 lbs.
30, 35, 60, 70	264 lbs.	359 lbs.
40, 80	284 lbs.	389 lbs.

VFD Enclosure Weight Adder

Small Enclosure, VFD 1-5 HP	95 lbs.
Large Enclosure, VFD 7.5-15 HP	135 lbs.

**Indoor Arrangement [IA] "B, D, G, K"
Shipping Weights (lbs.)**

Capacity [CA]	Arrangement [IA]			
	B	D	G	K
10	637	803		929
15	662	828		954
20	785	982	972	1103
25	812	1009	1021	1149
30	937	1163	1186	1321
30	983	1209	1238	1374
40	1048	1287	1314	1460
50	1144	1340	1349	1476
60	1318	1543	1565	1701
70	1389	1613	1634	1770
80	1490	1729	1748	1893
12			2181	

XIV. COIL CABINET DIMENSIONAL DATA

Figure 14

UNIT SIZE	"L" INSIDE MAX. CABINET OPENING
10/15	31-1/4" (794)
20/25/50	42-1/4" (1073)
30/35/60/70	53-1/4" (1353)
40/80	58-3/4" (1492)

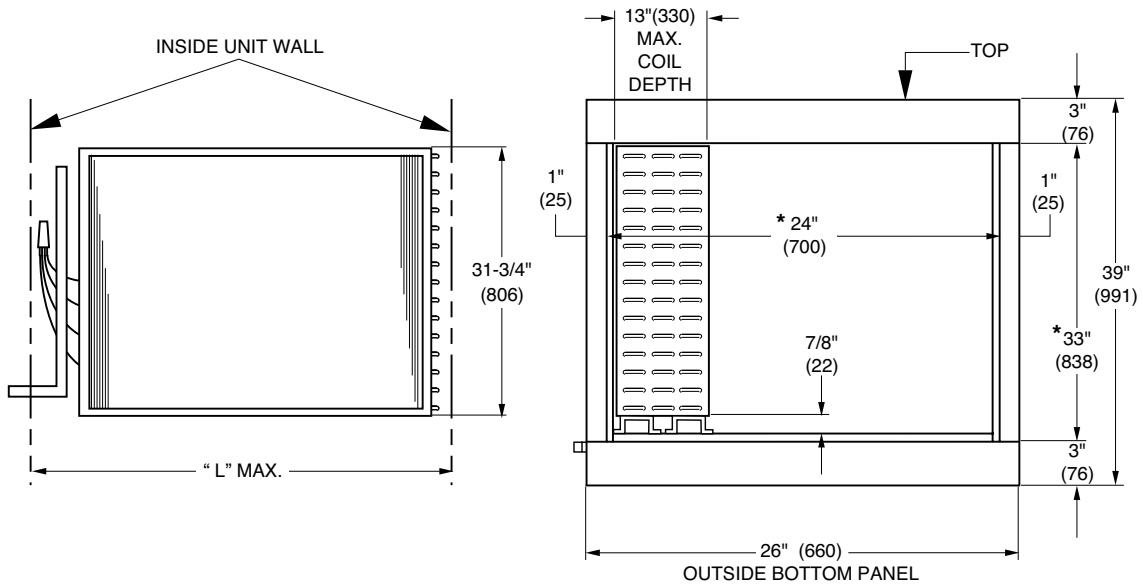

Maximum Coil Dimensions

Side Opening of Coil Module

XV. CENTER OF GRAVITY

Figure 15

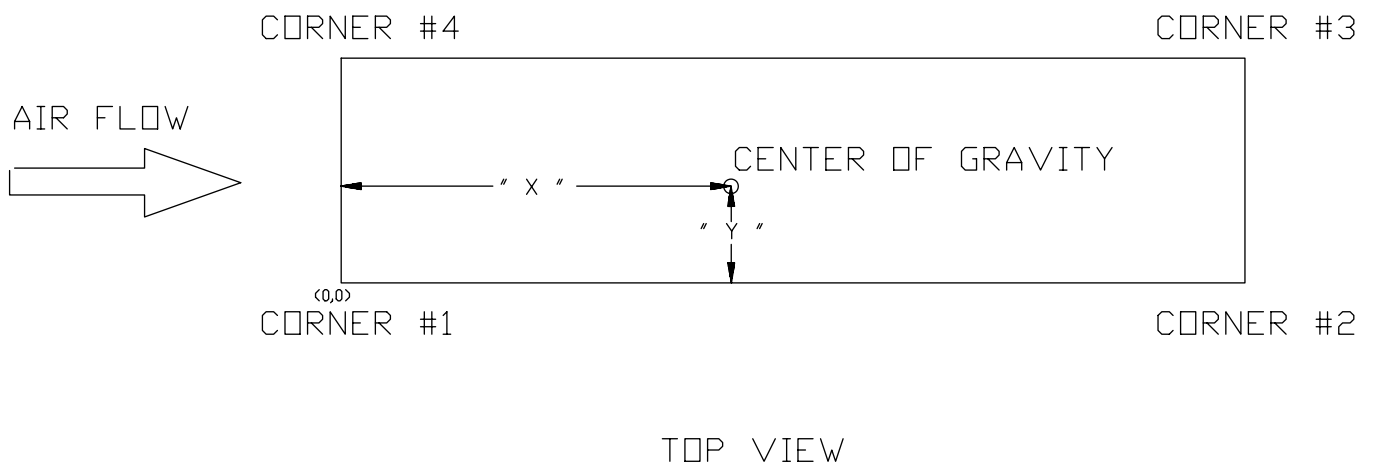

CENTER OF GRAVITY– refer to Figure 15

Values Based on Average Motor Weight and Average Coil Size (Arrangement K)

(Actual Center of Gravity and Corner Weights For Specific Motor Size and Specific Coil are Available Upon Request)

Unit Type, Capacity	Width	Length	ARRANGEMENTS "B" & "D" Without Outside Air Hood							ARRANGEMENT "G" Without Outside Air Hood						
			Center of Gravity		Corner Weights (lbs)				Center of Gravity		Corner Weights (lbs)					
			X-Coor	Y-Coor	Corner #1	Corner #2	Corner #3	Corner #4	X-Coor	Y-Coor	Corner #1	Corner #2	Corner #3	Corner #4		
ME10	32.75	72	35.8	15.4	161	159	141	142	N/A	N/A	N/A	N/A	N/A	N/A		
ME15	32.75	72	36.7	15.4	163	169	150	145	N/A	N/A	N/A	N/A	N/A	N/A		
ME20	43.75	72	36.2	20.6	195	196	174	173	59.6	20.7	223	274	246	200		
ME25	43.75	72	37.0	20.6	197	207	185	175	60.5	20.8	229	292	264	207		
ME30	54.75	72	37.2	25.2	230	246	209	196	61.5	25.4	266	351	304	230		
ME35	54.75	72	37.2	25.1	243	260	219	205	60.9	25.1	283	365	308	239		
ME40	60.25	72	37.8	27.9	253	278	239	217	61.1	27.9	295	385	332	255		
ME50	43.75	98	50.7	20.8	275	294	267	250	75.0	20.9	301	382	350	275		
ME60	54.75	98	50.7	25.6	318	340	299	280	75.4	25.7	348	448	396	308		
ME70	54.75	98	50.9	25.6	336	362	317	294	75.2	25.5	368	471	410	320		
ME80	60.25	98	51.6	28.3	353	391	347	313	75.4	28.3	389	500	443	344		
ME12	60.25	124	65.0	28.6	456	503	454	412	89.5	28.5	485	615	553	435		

Unit Type, Capacity	Width	Length	ARRANGEMENT "K" with CHILLED WATER COIL Without Outside Air Hood							ARRANGEMENT "K" with DX COOLING COIL Without Outside Air Hood						
			Center of Gravity		Corner Weights (lbs)				Center of Gravity		Corner Weights (lbs)					
			X-Coor	Y-Coor	Corner #1	Corner #2	Corner #3	Corner #4	X-Coor	Y-Coor	Corner #1	Corner #2	Corner #3	Corner #4		
ME10	32.75	134	70.0	15.8	254	278	259	237	73.0	15.7	217	259	239	200		
ME15	32.75	134	71.2	15.9	254	288	271	239	74.3	15.8	217	269	252	203		
ME20	43.75	134	71.7	21.1	287	330	306	266	74.4	21.0	249	311	287	229		
ME25	43.75	134	72.8	21.1	293	348	324	273	75.5	21.0	255	329	305	236		
ME30	54.75	134	73.9	26.1	330	407	370	301	73.9	26.1	330	407	370	301		
ME35	54.75	134	73.9	25.9	343	422	379	308	76.3	25.8	305	403	359	272		
ME40	60.25	134	74.3	28.7	357	444	403	324	76.6	28.6	319	426	383	288		
ME50	43.75	160	87.2	21.1	377	452	420	351	90.4	21.0	336	436	403	311		
ME60	54.75	160	87.5	26.0	430	518	468	388	90.3	25.9	388	503	451	348		
ME70	54.75	160	88.5	25.8	443	548	488	394	91.2	25.7	402	532	470	355		
ME80	60.25	160	89.2	28.6	462	582	525	416	91.9	28.5	421	567	508	377		

XVI. UNIT NUMBER DESCRIPTION INDOOR MAKE-UP AIR UNITS

Digit	M	X	X	-	1	2	3	4	5	6	7	8	9	10	11	12	13	14	15	16	17	+
Item	Prefix				UT	CA		FT	FM	IA	CO	GT	GC	SV	MT	MS	AI	AC	AS			
	(Internal use Only)																					

1, 2 - Unit Type [UT]

ME - Power Vented Indoor Make-up Air Unit

3, 4 - Capacity [CA]

Single Furnace

10 - 100,000 BTU/HR
15 - 150,000 BTU/HR
20 - 200,000 BTU/HR
25 - 250,000 BTU/HR
30 - 300,000 BTU/HR
35 - 350,000 BTU/HR
40 - 400,000 BTU/HR

Double Furnace

50 - 500,000 BTU/HR
60 - 600,000 BTU/HR
70 - 700,000 BTU/HR
80 - 800,000 BTU/HR

Triple Furnace

12 - 1,200,000 BTU/HR

5 - Furnace Type [FT]

A - Standard Temperature Rise (30-80° F) Right Side Access
B - Standard Temperature Rise (30-80° F) Left Side Access
0 - None
Z - Other

6 - Furnace Construction Material [FM]

1 - Aluminized Steel
2 - 409 Stainless Steel (First Furnace Only)
3 - 409 Stainless Steel (All Furnace Sections)
4 - 321 Stainless Steel (First Furnace Only)
5 - 321 Stainless Steel (All Furnace Sections)
6 - 409 Stainless Steel Package (First Furnace Only)
7 - 409 Stainless Steel Package (All Furnace Sections)
8 - 321 Stainless Steel Package (First Furnace Only)
9 - 321 Stainless Steel Package (All Furnace Sections)
0 - None
Z - Other

7 - Indoor Arrangement (includes furnace section(s) [IA])

A - Duct Furnace (50/12 [CA] only) K - Blower (High CFM) / Cooling
B - Blower (Standard) 0 - None
D - Blower (Standard) / Evap. Z - Other
G - Blower (High CFM)

8 - Coil Options [CO]

A - DX Coil, 4 Row Single Circuit E - Chilled Water Coil, 4 Row
B - DX Coil, 4 Row Dual Circuit G - Chilled Water Coil, 6 Row
C - DX Coil, 6 Row Single Circuit 0 - None
D - DX Coil, 6 Row Dual Circuit Z - Other

9 - Gas Type [GT]

1 - Natural Gas
2 - LP Gas (Propane)
3 - Natural Gas w/100% Lockout
0 - None

10 - Gas Control [GC]

A - Single Stage Gas (Standard)
B - Two Stage Gas
H - Electronic Modulation w/Room Sensing
J - Electronic Modulation w/Duct Sensing
K - Electronic Modulation w/Duct Sensing & Ovrd. Stat
L - Electronic Modulation w/External 4-20 mA Input (Furnace One)
M - Electronic Modulation w/External 4-20 mA Input (All Furnaces)
N - Electronic Modulation w/External 0-10 VDC Input (Furnace One)
P - Electronic Modulation w/External 0-10 VDC Input (All Furnaces)
R - Two Stage Remote Temperature Control w/Duct Sensor
S - Three Stage Remote Temperature Control w/Duct Sensor
T - Four Stage Remote Temperature Control w/Duct Sensor
U - S-350 2 Stage Modular Electronic Control System
W - S-350 3 Stage Modular Electronic Control System
X - S-350 4 Stage Modular Electronic Control System
Y - S-350 6 Stage Modular Electronic Control System
0 - None
Z - Other

11 - Supply Voltage [SV]

1 - 115/1/60 5 - 230/3/60
2 - 208/1/60 6 - 460/3/60
3 - 230/1/60 7 - 575/3/60
4 - 208/3/60 0 - None
 Z - Other

12 - Motor Type [MT]

1 - Open Drip Proof (Standard)
2 - Totally Enclosed
3 - Premium Efficiency, Open Drip Proof
4 - Premium Efficiency, Totally Enclosed
0 - None
Z - Other

13 - Motor Sizes [MS]

A - 1/2 HP. w/Contactor M - 1-1/2 HP. w/Mag. Starter 1 - 1 HP. VFD
B - 3/4 HP. w/Contactor N - 2 HP. w/Mag. Starter 2 - 1-1/2 HP. VFD
C - 1 HP. w/Contactor P - 3 HP. w/Mag. Starter 3 - 2 HP. VFD
D - 1-1/2 HP. w/Contactor R - 5 HP. w/Mag. Starter 4 - 3 HP. VFD
E - 2 HP. w/Contactor S - 7-1/2 HP. w/Mag. Starter 5 - 5 HP. VFD
G - 3 HP. w/Contactor T - 10 HP. w/Mag. Starter 6 - 7-1/2 HP. VFD
H - 5 HP. w/Contactor U - 15 HP. w/Mag. Starter 7 - 10 HP. VFD
J - 1/2 HP. w/Mag. Starter 0 - None 8 - 15 HP. VFD
K - 3/4 HP. w/Mag. Starter Z - Other

14 - Air Inlet Configuration [AI]

1 - Outside Air (OA) 4 - Outside Air and Return Air (OA/RA)
2 - Outside Air w/Air Hood* 5 - Outside and Return Air w/Air Hood*
3 - Return Air (RA) 0 - None
 Z - Other

*Hood shipped separately

15 - Air Control & Damper Arrangement [AC]

A - Outside Air 2 Pos. Motor / Spring Return
B - Return Air 2 Pos. Motor / Spring Return
C - OA/RA 2 Pos. / Spring Return
E - OA/RA Mod. Mtr. w/Mixed Air Control / Min. Pot. / SR
H - OA/RA Mod. Mtr. w/Mixed Air Control / SR
K - OA/RA Mod. Mtr. w/Min. Pot. / SR
M - OA/RA Mod. Mtr. w/Dry Bulb / Mixed Air Control / Min. Pot. /SR
N - OA/RA Mod. Mtr. w/Enthalpy Controlled Economizer / SR
P - OA/RA Mod. Mtr. w/Pressure Control (Space Pressure)
Q - OA/RA Mod. Mtr. w/Carbon Dioxide (CO₂) R/A Monitor
R - OA/RA Mod. Mtr. w/S-350-P Proportional Mixed Air Control / SR
T - OA/RA Mod. Mtr. w/0-10 VDC & 4-20 mA Analog Input / SR (External Input)
U - ASHRAE Cycle I (OA/RA 2 Pos. Mtr. w/Warm-up Stat / SR)
W - ASHRAE Cycle II (OA/RA Mod. Mtr. w/Warm-up Stat / Mixed Air / Min. Pot. / SR)
X - ASHRAE Cycle III (OA/RA Mod. Mtr. w/Warm-up Stat / Mixed Air / SR)
Y - Manual Dampers
0 - None MOD = Modulating Damper Motor
Z - Other OA = Outside Air RA = Return Air SR = Spring Return

16 - Accessories [AS]

A1 - Moisture Eliminator H1 - Return Firestat
A2 - Horizontal Return H2 - Supply Firestat
A3 - Low Leak Damper H3 - Freezestat w/ Time Delay
A5 - Furnace Drip Pan, 409 Stainless H4 - Ambient Lockout - Single Furnace
A6 - High Altitude Unit H6 - Ambient Lockout - Dual Furnace
A7 - High Pressure Regulator H7 - Ambient Lockout - Triple Furnace
 A7 - 1/2-1 Regulator for 0.5-10 PSI
 A7 - 3/8-1 Regulator for 10-20 PSI
 A7 - 5/16-1 Regulator for 20-35 PSI
A8 - Unit Derate

B1 - Filters - 1" WA (Standard)
B2 - Filters - 2" WA
B3 - Filters - 2" TA
B4 - Filters - 1" 30%
B5 - Filters - 2" 30%

C1 - Evap. Cooler - Fill & Drain Kit
C2 - Evap. Cooler - 12" Celdek® Media
C3 - Evap. Cooler - Freezestat
 w/0 Time Delay
C4 - Evap. Cooler - 8" Glasdek® Media
C5 - Evap. Cooler - 12" Glasdek® Media

D1 - Time Clock - 7 Day †
D2 - Time Clock - 24 Hour †
D6 - Pre-Purge Delay, 60 s.

E1 - Clogged Filter Switch
E2 - G.F.I. Convenience Outlet 115VAC †
E3 - Remote Control Panel †
E4 - Manual Blower Switch

F1 - Ductstat - One Stage †
F2 - Ductstat - Two Stage †

G1 - Thermostat - T87K w/Subbase †
G2 - Thermostat - T87K w/Subbase & Guard †
G3 - Thermostat - T834N w/Subbase (Sterling Stat) †
G4 - Thermostat - TH8320R - 7 Day Programmable †
G5 - Thermostat - TH5220D (Two Stage) †
G6 - Locking Thermostat Cover †
Note: All thermostats are Mercury free † = Field Installed

J1 - Interlock Relay - 24V Coil DPDT 10A, Plug-in
J2 - Interlock Relay - 24/115V Coil SPDT 10A
J3 - Interlock Relay - 24/115/230V Coil DPDT 10A
J4 - Interlock Relay - 24V Coil I 4PDT 10A

K1 - Manual Reset High Limit Switch †
K2 - High / Low Gas Pressure Limit Switches
K3 - Status Lamp (Elec. Cabinet)
K4 - Fan Time Delay (Arrangement "A" Only)
K5 - Air Flow Prove Switch (Dwyer 1910-0) †

L1 - 30 Amp, Fused Disconnect Switch †
L2 - 30 Amp, Non Fused Disconnect Switch †
L3 - 60 Amp, Fused Disconnect Switch †
L4 - 60 Amp, Non Fused Disconnect Switch †

M2 - Vent Caps †
M3 - Flue Adapter(s) (4-5 inches) †

N5 - Service Convenience Package
N6 - Double Wall Construction

R1 - Field Installed VFD
R2 - Factory Installed VFD
R3 - VFD Remote Keypad for use w/R1 †
R4 - CO₂ Sensor - 100% OA †
R5 - CO₂ Sensor - Mixed Air †
R6 - Pressure Sensor †
R7 - 2-Speed VFD Relays
R8 - 3-Speed VFD Relays
R9 - VFD Enclosure, for use w/R2

0 - None
Z1 - Other (Specify)

INDOOR MAKE-UP AIR PRODUCTS Submittal Index (Single Furnace Units)

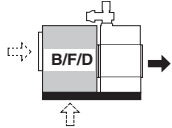
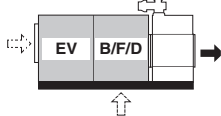
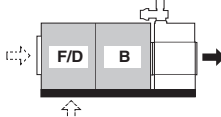
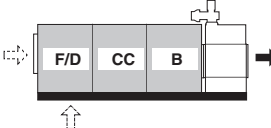
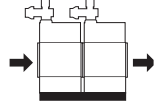
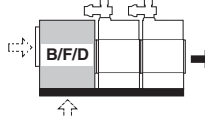
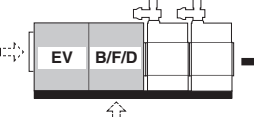
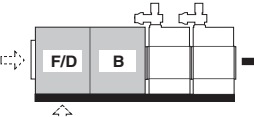
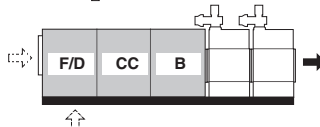
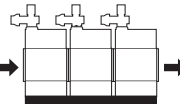
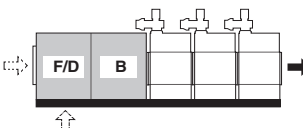
	Unit Type (UT) Power Venting (ME)	Submittal Number
IA "B" CA (10/40)		ME-40-B
IA "D" CA (10/40)		ME-40-D
IA "G" CA (10/40)		ME-40-G
IA "K" CA (10/40)		ME-40-K
IA "A" CA (50/80)		ME-80-A
IA "B" CA (50/80)		ME-80-B
IA "D" CA (50/80)		ME-80-D
IA "G" CA (50/50)		ME-80-G
IA "K" CA (50/80)		ME-80-K
IA "A" CA 12		ME-12-A
IA "G" CA 12		ME-12-G

IA = Indoor Arrangement (Digit #7)
 CA = Capacity (Digits #3 and 4)
 Air Inlet Configurations may vary (Digit #14)
 Refer to complete Model Number Designation for more details.

Legend: B/F/D = Standard Blower/Filter/Damper Module
 B = Hi CFM Blower Module
 F/D = Hi CFM Filter/Damper Module
 CC = Cooling Coil Module
 EV = Evap. Cooler Module

